



Electric service handbook

Revised March 21

Electric construction

Section: Electric service handbook

Table of contents

Section 1:	Introduction.....	1-001
Section 2:	AES Ohio Offices.....	2-001
Section 3:	General Information.....	3-001 to 003
Section 4:	Metering Information.....	4-001 to 004
Section 5:	Distribution Systems Available	
	• Alternating Current Services.....	5-001, 002
	• Alternating Current Services – High Voltage.....	5-002
	• Central Business District.....	5-003
Section 6:	Service Installations.....	6-001
Section 7:	Expressway Lighting	
	Pole Mounted Metering for 3W, 480V Service.....	7-001
Section 8:	Points of Attachment	
	Installation of Customer Antennas and Other Devices.....	8-001
	Overhead Services – Under 600 V.....	8-0020, 003
Section 9:	Swimming Pools	
	Clearances to Open Supply Conductors.....	9-001
	Clearances to Triplexed Cable.....	9-002
Section 10:	Underground Distribution Services	
	Residential URD – Secondary Services	
	• Transformer Rated Metering.....	10-001
	• Self-Contained Metering.....	10-002
	Residential URD – 400 AMP and Smaller Services	
	• Single Phase 3W, URD.....	10-003
	URD – 200 AMP and Smaller Services	
	• 3 Phase, 4W, Wye, URD.....	10-004
	• 3 Phase, 4W, Delta, URD.....	10-005
	URD – 401 to 1200 AMP Services	
	• Single Phase, 3W, URD.....	10-006

Table of contents

Section 10 (continued):

- URD – 201 to 1200 AMP Services with Current Transformer
 - 3 Phase, 4W, Wye, URD 10-007
 - 3 Phase, 4W, Delta, URD 10-008
- Commercial Pad-Mounted Transformer Services
 - 1 Phase, Self-Contained Meter Installation 10-009
 - Multiple Meter Installations 10-010
 - Metering Cabinet on Pad 10-011
- URD – Miscellaneous
 - Duct & Trenching – Secondary Cable Routing 10-012
 - URD Temporary Service (Single Phase, 3W) 10-013
 - Free Standing or Trailer Installation – URD 10-014
 - Commercial 100 Amp and Smaller Street Lighting 10-015

Section 11:

- Overhead Services
 - 200 AMP and Smaller
 - Single Phase, 3W, OVHD without Mast 11-001
 - 200 AMP and Smaller
 - Single Phase, 3W, OVHD with Mast 11-002
 - 200 AMP and Smaller
 - 3 Phase, 4W, Wye, OVHD 11-003
 - 3 Phase, 4W, Delta, OVHD 11-004
 - 401 to 1200 AMP Services
 - Single Phase, 3W, OVHD 11-005
 - 3 Phase, 4W, Wye, OVHD 11-006
 - 3 Phase, 4W, Delta, OVHD 11-007
 - Overhead Services – Miscellaneous
 - Overhead Territory 11-008
 - Temporary Service 11-009
 - Trailer Installation 11-010

Electric construction

Section: Electric service handbook

Table of contents

Section 12:	Customer Owned Services	
	Center Pole – Transformer Rated Metering.....	12-001
	Meter & Service Pole Self Contained Installation.....	12-002
Section 13:	Grouped Meter Centers	
	Commercial Grouped Meter Centers 200A and Less	13-001
Section 14:	GenerLink™ Transfer Switch	
	Meter Socket Based Transfer Switch.....	14-001
Section 98:	Service Lateral Requirements	
	Residential – 1 Family URD	98-001
	Residential – 2 Family URD	98-002
	Residential – Multiple Meters Center URD.....	98-003
	Commercial – Single Meter from Existing Facilities-URD.....	98-004
	Commercial – Single Meter from New Facilities-URD	98-005
	Commercial – Multiple Meters Center-URD from Existing Facilities.....	98-006
	Commercial – Multiple Meters Center-URD from New Facilities	98-007
	Commercial – Many Service Conductors	98-008

Electric construction

SH-01-001

Section: Electric service handbook

Introduction

This handbook is published to give customers, architects, engineers, builders, and electricians general information about routine electric service to new and remodeled buildings. It also provides information regarding the installation of electrical equipment to be serviced from AES Ohio's electric distribution system.

The information is based on accepted standards in the industry. It is intended to ensure safe, quality, uniform and economical service to our customers.

This booklet is not all inclusive. For situations not covered, contact AES Ohio Construction Control center for the appropriate area.

This Handbook is in addition to and is intended to be in conformance with the Schedule of Rates, Classifications, Rules and Regulations of the company as filed with the Public Utilities Commission of Ohio (PUCO). This handbook is also intended to be in conformance with the National Electrical Safety Code (NESC).

Contacts

aes-ohio.com/construction

Construction control center: 800-424-5578

Rev. March-21

Replaces: July-19

Report an outage:

877-468-8243

www.aes-ohio.com



Electric construction

SH-02-001

Section: Electric service handbook

AES Ohio offices

AES Ohio furnishes electric service throughout West Central Ohio. Information about service can be obtained from any of the following service centers:

Construction Control Center

1900 Dryden Road
Dayton, OH 45439
Phone: 937-331-4860
Toll Free: 800-424-5578

Electric Meter Department

1900 Dryden Road
Dayton, OH 45439
Phone: 937-331-4549

Customer forms mentioned in this book and approved meter socket list can be found at <https://www.aes-ohio.com/customer-service/account-center/start-or-stop-service/construction/>

Contacts

[aes-ohio.com/construction](https://www.aes-ohio.com/construction)

Construction control center: 800-424-5578

Rev. March-21

Replaces: July-19

Report an outage:

877-468-8243

www.aes-ohio.com



Electric construction

SH-03-001

Section: Electric service handbook

General information

Obtaining electric service

Anyone needing new service or changes to existing service should contact the Construction Control Center to obtain an Electrical Service Information Form (ESIF). In order to assure that electric service is ready when needed, please make your requests early and keep AES Ohio informed of your progress.

Access to premises

To provide for the best possible service, it may be necessary for AES Ohio representatives to enter the customer's premises during reasonable hours. Reasons include reading meters, examining and inspecting wiring, installing equipment, testing services, inspecting and repairing equipment, and removing equipment owned by AES Ohio. The AES Ohio representative will, upon request, show his company identification and state the reasons for requesting entry.

Relocation of service facilities

Requests by customers for relocation of electric service facilities should be made by contacting the Construction Control Center. Relocation fees could apply.

Compliance with codes

All customer wiring, appliances, and services connected directly or indirectly to AES Ohio's service facilities will be installed to conform with the latest provisions of applicable federal, state, county, and municipal codes and/or with the provisions of the National Electrical Code (N.E.C.). Service shall not be rendered until wiring has been inspected and approved by the inspecting authority having jurisdiction. In areas where there is no inspecting authority, the "Form for Energizing Service Inspected by Licensed Electrician" must be completed by a State of Ohio licensed electrician or State of Ohio Professional Engineer. AES Ohio reserves the right not to connect any service it deems unsafe. In case of apparent or actual conflict, you should contact the Construction Control Center.

Point of delivery

The "point of delivery" of electricity supplied by AES Ohio is the point where the electricity enters the service entrance conductors or equipment of the customer. This definition will apply unless otherwise specified by special contract or as shown on the following pages. AES Ohio designates the "point of delivery." All equipment on the load side of the "point of delivery" is owned, operated, and maintained by the customer, unless otherwise specified. The meter is always the property of AES Ohio.

Responsibility after electricity is delivered

The customer will provide, install, operate, and maintain the service entrance wiring and all other wiring, appliances, and devices necessary to receive the electricity supplied from and after the point of delivery. Customer is responsible for installation of both new and replacement meter boxes.

Contacts

aes-ohio.com/construction

Construction control center: 800-424-5578

Rev. March-21 Replaces: July-19

Report an outage:

877-468-8243

www.aes-ohio.com



General information

IMPORTANT NOTICE

Where the customer installs his own electric generation equipment, it is absolutely necessary that every precaution be taken to prevent back-feeding of customer's electricity into AES Ohio's distribution system. Occurrence of backfeeding could result in loss of equipment, serious injury or death to personnel.

SEE SH-14-010.

Emergency and auxiliary service

A customer maintaining his own electric generating equipment who desires to use AES Ohio's electrical service must contact the Construction Control Center for information regarding the connection and operation of his equipment.

Residential services

AES Ohio will not install secondary or primary services under, or through buildings, or walls. AES Ohio recommends that customers on the underground residential distribution system (URD) install UL listed Schedule 40 conduit (2.5 inches minimum) from within 2 feet of the customer's point of attachment up to within 2 feet of the supply facility.

OUPS

The Ohio Utilities Protection Service (OUPS) is a centralized source of information about underground utilities. A telephone call to OUPS will provide you with prompt identification and physical marking of underground electric, gas, telephone, and water facilities. You should use this service whenever you are going to excavate.

By simply calling OUPS two working days before digging, all member utilities in the area will be notified. The OUPS telephone number is:

1-800-362-2764

Trenches

Please contact OUPS before conducting any trenching. All trenches must meet AES Ohio clearance codes for all services as well as pertinent local, state, or national ordinances. The customer is responsible for digging and backfilling trenches on the customer property. The customer is to dig to within 2 feet of AES Ohio's supply facility. The customer must remove all foreign material, rocks, and sharp objects from backfill material (Refer to sheet SH 10-050-01 of this handbook for additional information on trenching). All trenches are subject to inspection by AES Ohio for compliance before any AES Ohio cable or equipment is placed into them.

SERVICE MAST

All overhead service masts will be rigid galvanized steel conduit with a minimum length of 7 feet and minimum diameter of 2.5 inches. Installations of masts other than described above must be approved by AES Ohio Engineering.

Electric construction

SH-03-003

Section: Electric service handbook

General information

Electrical conduit

Where required by AES Ohio, electrical conduit located on customer property will be supplied and installed by the customer. UL listed Schedule 40 (2.5" minimum) conduit is required under decks, paved and concrete surfaces or in unusually rocky soil. SEE Table SH-06-010.

Internal meter bypass lever switch

All self-contained meter sockets installed for commercial and industrial customers will have a bypass handle for each metered position. This includes multimeter centers.

Installing signs, antennas, flag poles, or light posts

When installing signs, antennas, poles, or posts near an electrical service, the customer must comply with all applicable ordinances, codes, and AES Ohio standards.

All customers desiring to install any sign (including motorized signs), antenna, pole, or post within 25 feet of AES Ohio services (power lines, underground cable, poles, transformers, etc.) must contact the Construction Control Center.

Service entrance on or in buildings

Service entrance conductors will be enclosed in either an approved cable assembly or in conduit and will be exposed to view.

Number AES Ohio services

Only one AES Ohio service drop or lateral will be supplied for each residential building. AES Ohio will only install overhead commercial and industrial service drops (one per building).

Service connection

After release from state and local inspection agencies, AES Ohio will make the final connection between its supply equipment and the customer's service entrance equipment. AES Ohio will not permit unauthorized persons to make service connections.

Contacts

aes-ohio.com/construction

Construction control center: 800-424-5578

Rev. March-21

Replaces: July-19

Report an outage:

877-468-8243

www.aes-ohio.com



Metering information

General

Meters will be furnished and installed by AES Ohio. Service shall not be rendered until wiring is inspected and approved by the inspecting authority having jurisdiction. In the absence of an inspecting authority, having jurisdiction, the "Form for Energizing Service Inspected by Licensed Electrician" must be completed by a State of Ohio licensed electrician or State of Ohio Professional Engineer. All equipment furnished by AES Ohio will remain AES Ohio property. Representative meter installation standard prints are shown in the handbook (these are subject to change).

Meter locations

Each customer will provide, without charge to AES Ohio, a suitable location for meters and metering equipment. AES Ohio retains the right to make a final determination of the location of the meters or metering equipment on the customer's premises.

Meters shall be located on the outside of the building unless otherwise approved by AES Ohio.

Meters will not be mounted on switchboards or metal frames unless approved by AES Ohio. Electric meter socket must have 3 feet clearance from the nearest point of a gas meter setting.

When choosing a location for metering equipment, sufficient clearance must be provided so that the doors of all cabinets and switches can be completely opened. Not less than 3 feet of clean, unobstructed space will be provided and maintained in front of all metering equipment. In the case of machinery with unguarded moving parts, changes in floor level, etc., a clear distance of 6 feet must be provided in front of all meters. A clearance of at least 6 inches must be provided between the nearest obstruction above and on each side of any single meter or group of meters. When meters are mounted in a group and space is limited, special layouts must be obtained from AES Ohio before proceeding with the installation of equipment.

Meter installations

The type of meter installation to be installed will be determined by the size and character of the customer's load and the type of service to be supplied.

AES Ohio's meter equipment will be installed to conform to specifications and drawings prepared by AES Ohio. AES Ohio will be consulted on all commercial, industrial, center pole, and grouped meter installations.

Meter sockets and meter boxes

For all new and reconstructed alternating current service installations, meter sockets and meter boxes will be furnished and installed by the customer. Unless otherwise designated and approved by AES Ohio, the meter will be connected on the supply side of the customer's service equipment.

Metering information

Where meter sockets, meter boxes, and similar equipment are mounted on the outside of the structure, additional backing will be provided for securing this equipment to the siding unless equipment mounting screws are set into the studding. Screws installed in soft wood siding and siding shingles backed with insulating board or similar material are not considered securely anchored. Equipment mounted on brick, stone, concrete, concrete block, hollow tile, or plastered walls are not considered securely fastened unless installed with toggle bolts, screws set in metal anchors or expanded shields.

In general, meter socket, service equipment, and meter installation equipment will be arranged so that the top of the meter socket is between 42 inches and 66 inches from the floor or final grade. Exceptions may be made where this is not practical.

Meter board

Where meter sockets, meter boxes, and similar equipment are mounted indoors and a meter board is required, the meter board will be provided by the customer. The meter board will be good quality solid lumber or plywood (at least $\frac{3}{4}$ inch nominal thickness) fastened rigidly to the wall in a vertical position. When mounting in basements or other areas subject to moisture, an air space must be provided between the meter board and the wall.

All electrical contractors or electricians are required to put their name, address, and telephone number on the meter board. This information will enable AES Ohio to contact them, if necessary.

Meter centers

It is recommended that the customer consult with AES Ohio when prefabricated meter centers are being considered for a grouped meter installation. Such equipment will be furnished and installed by the customer, after AES Ohio gives specific approval of the meter center. All single-phase and three-phase commercial grouped meter centers will have a bypass handle for each meter. Meter Centers are not approved for 480 volt services. See "Approved Meter Socket" on <https://www.aes-ohio.com/customer-service/account-center/start-or-stop-service/construction/>

Grouped meter installations

Where two or more customers occupying the same building are served by separate meters, and a suitable location accessible to all customers is available, all meters may be grouped together.

Where meters are grouped together, the installer must permanently tag each service to indicate which portions of the building are supplied by each service before service will be established.

Unmetered conductors

Unmetered conductors will not be permitted in any raceway, pull-box, distribution panel, or similar device containing metered conductors.

AES Ohio reserves the right to restrict the use of certain fittings and cabinets in raceways and meter sockets containing unmetered conductors.

Metering information

Instrument transformers

Instrument transformers, where required for service installations metered at secondary voltages, will be furnished by AES Ohio and installed by the customer.

The secondary wiring of metering transformers normally will be furnished and installed by AES Ohio. However, in certain cases AES Ohio may require the customer to install secondary wiring furnished by AES Ohio. All final wiring connections to meters, associated metering equipment, and metering transformers will be made by AES Ohio.

Instrument transformer cabinets

Approved metal or PVC cabinets enclosing instrument transformers will be furnished and installed by the customer. Cabinets and installation practices must meet AES Ohio specifications.

The customer may, after AES Ohio's approval, install instrument transformers in metal-clad switchgear if a separate, sealable cubicle or compartment is provided and the transformers are installed so they can be readily replaced. The minimum size for a single phase instrument transformer cabinet for services below 800 amps is 24" x 32" x 10" (H x W x D.) The minimum size for a single phase instrument transformer cabinet for services from 800 amps to 1200 amps is 32" x 36" x 10: (H x W x D). The minimum size for a three phase instrument transformer cabinet for services below 800 amps is 32" x 36" x 10" (H x W x D.) The minimum size for a three phase instrument transformer cabinet for services from 800 amps to 1200 amps is 48" x 48" x 12" (H x W x D). All instrument transformer cabinets must be mounted a minimum of 18" from the bottom of the cabinet to final grade and no more the 66 inches to the top of the cabinet from final grade. Any services larger than 1200 amps, please contact the Electric Meter Department.

The customer will furnish and install a 1.25-inch minimum rigid rated conduit between the instrument transformer compartment and the meter mounting for the metering cable.

Instrument transformer cabinets will not be used as junction boxes. Service conductors will enter and leave the cabinet as one circuit regardless of the number of conductors per phase. When approved by AES Ohio, instrument transformers may be installed at the service head of overhead services. In such cases, they can be mounted on a pole, service mast, or building wall at a height not to exceed 22 feet.

Metering over 600 volts

Contact the Construction Control Center.

Electric construction

SH-04-004

Section: Electric service handbook

Metering information

AES Ohio will not permit any metering equipment to be installed on or in any Pad Mount Transformers

Sealing of meters and devices

AES Ohio will seal all meters and all enclosures that contain meters, associated metering equipment, AES Ohio controlled load interrupting devices, or unmetered wiring. AES Ohio will not permit unauthorized persons, to break meter seals, or open any wires or switches in connection with the meter wiring and service facilities.

Contacts

aes-ohio.com/construction

Construction control center: 800-424-5578

Rev. March-21 Replaces: July-19

Report an outage:

877-468-8243

www.aes-ohio.com



Distribution systems available

General

The customer should consult with the Construction Control Center for a service location and the type of service available. AES Ohio's response should be received before purchasing electrical equipment for a new service, addition, or modification of an existing service, or before moving equipment to a new service address.

Failure to contact AES Ohio may result in the purchase or installation of electrical equipment that cannot be used at a specific location.

AES Ohio furnishes many different types of electrical service to our customers. Some things that determine the type of service furnished to a customer are the location in AES Ohio's territory, the size of the load, and the customer's electrical equipment. Some types of service may not be available at a specific location.

A description of the types of service and their use follows. All voltages and frequencies are listed as nominal per the current American National Standards Institute (ANSI) standard.

Alternating current service

- A. 120/240 volt or 240/480 volt, 60 hertz (cycles per second), single phase, three-wire service.

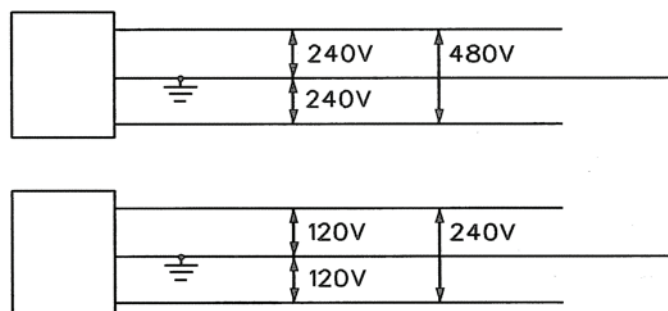

This service is available to all residential, commercial, industrial, and governmental customers. The customer must consult AES Ohio about service to single phase motors exceeding 5 horsepower.

This service is limited to a customer load of 300 KVA or smaller.

Electric construction

Section: Electric service handbook

Distribution systems available

B. 120/208 volt, 60 hertz (cycles per second), three phase, four wire, wye service. 277/480 volt, 60 hertz, three phase, four wire, wye service.

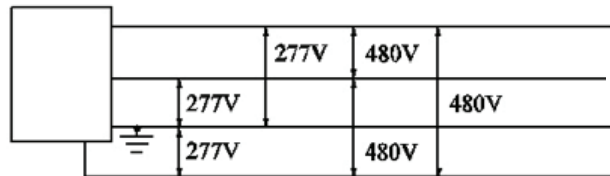
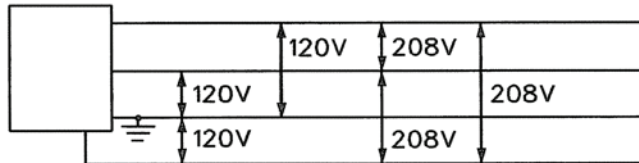

These services are available to commercial, industrial, and governmental customers at AES Ohio's option.

B. 120/240 volt, 60 hertz (cycles per second), three-phase, four wire delta

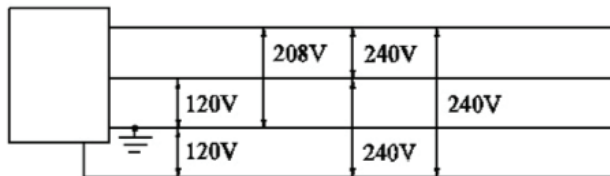

This service is available to commercial, industrial, and governmental customers at AES Ohio's option.

A. 120 volt, 60 hertz (cycles per second), single phase, two wire service.

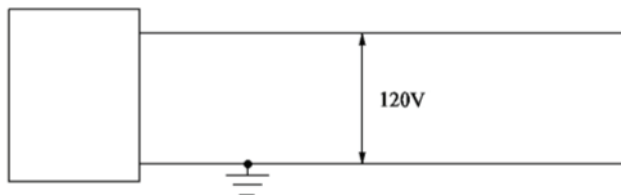

Alternating current service - higher voltages

Services above 600 volts are available at AES Ohio's option.

Contact the Construction Control Center.

Distribution systems available

Alternating current service – central business district, Dayton/Troy

277/480 volt, three phase, four wire wye; 120/208 volt, three phase four wire wye; and 120/208 volt, single phase, three wire services are available at AES Ohio's option in the downtown Dayton/Troy area.

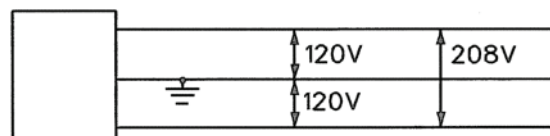
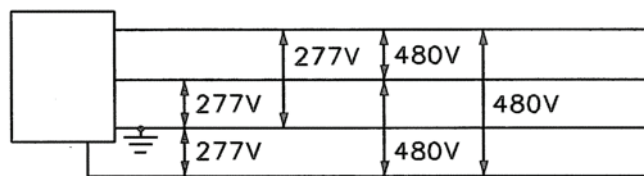
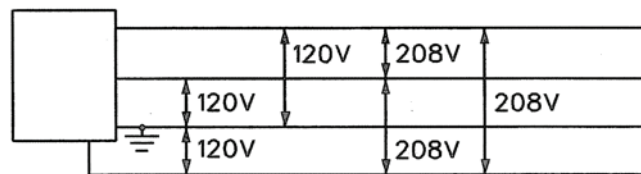

Network electric service

All new and upgraded single phase and three phase electric services originating from the 120/208Y networks or the 277/480Y spot networks on the AES Ohio Co. systems shall be constructed with a properly rated load break disconnect switch purchased and installed by the customer on the line side of their meter.

Each of these new or upgraded services energized from the network system shall be installed in a customer owned, U.L. approved wire-way from a AES Ohio Co. designated manhole or pull-box to the disconnect switch. The conduit wire-way shall be laced and sized to accommodate the service conductor owned and installed by the AES Ohio Co.

When an electric service originates from a network transformer vault which contains a network transformer and/or voltage bus-work, the customer shall be responsible for all conduit and electrical conductor from this vault to the main service disconnect switch.

Service installations

General

AES Ohio is interested in ensuring that quality electrical service is established in a timely and safe manner. Before electrical work is started on a residential, commercial, industrial, or governmental building, the owner, developer, or electrical contractor shall consult with the Construction Control Center to obtain an ESIF packet. AES Ohio will answer questions regarding metering, ownership, and installation responsibilities, available fault current, rates, motor starting limitations, and other concerns based on the information from the ESIF packet returned by the customer or their representative.

The customer's service entrance installation shall conform to the latest edition of the National Electrical Code (N.E.C.) and the information in this handbook.

AES Ohio underground residential services in conduit

It is recommended that conduit be installed for underground services. Conduit shall be buried with a minimum of 24 inches cover. The conduit should be installed in as straight a line as possible. Two 90-degree bends of 36-inch radius each are the maximum number allowed in each run of conduit unless AES Ohio Engineering approves alternatives. All conduit rising above grade must be schedule 40 or equivalent.

AES Ohio will not install cable into any conduit that is not UL listed.

Refer to N.E.C. for rules and regulations for grounding services at meter socket. Refer to N.E.C. for rules and regulations for the allowable number of disconnects per building.

Direct buried cable owned by AES Ohio will have a minimum of 24 inches of cover for cable rated 0 to 600 volts and a minimum cover of 30 inches for cable rated 601 to 50,000 volts. Where the surface is not to final grade or uniformly even, such as a slope, the cable shall be installed to meet the 30 inch cover at time of installation and subsequent thereafter.

Conduit sizing for underground services

The following table contains information on conduit sizes. AES Ohio's Engineering department may be contacted for additional information or questions.

Verification of any AES Ohio cable to be placed in customer conduit is required before customer installs conduit.

Multi Conductor Secondary Description	# of Multi-conductor Sets	
	1	2
	Conduit Size (inches)	
TRI 1/0-2 3/C AL	2½	3
TRI 4/0-2/0 3/C AL	2½	4
TRI 350 MCM-4/0 3/C AL	3	5
QUAD 4/0 4/C AL	3	4
QUAD 350 MCM 4/C AL	3	5
QUAD 500 MCM 4/C AL	3	5

Electric construction

SH-07-001

Section: Electric service handbook

Pole mounted metering for (3W, 240/480V) 400amp and below service

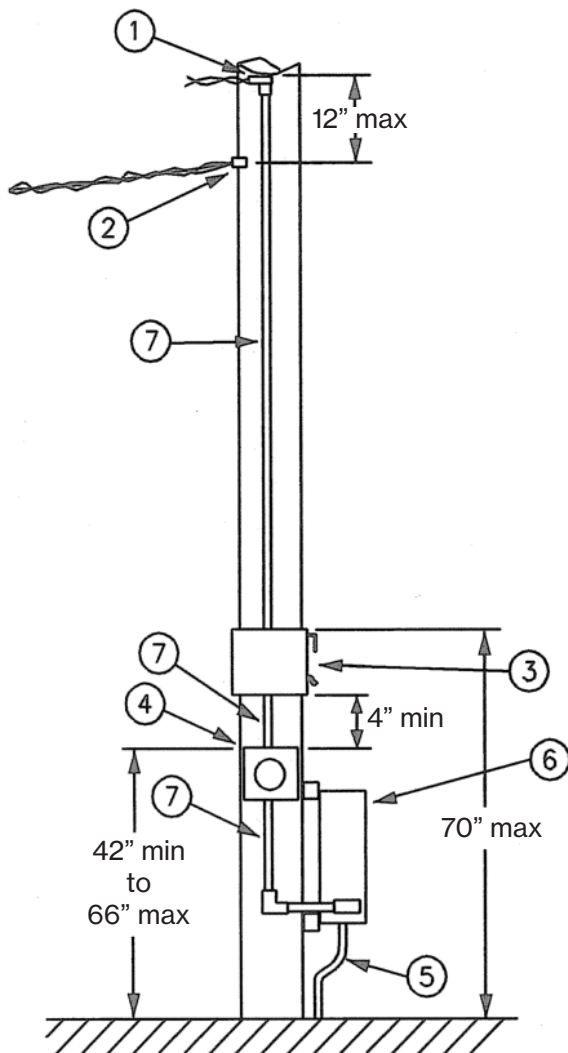

1. Service head shall be a maximum of 12" above the clevis. The minimum length of conductors out of the service head shall be 24".
2. Service drop furnished and installed by AES Ohio. AES Ohio will furnish the clevis and the customer will install it. AES Ohio will provide information on height, number, and direction of clevis. AES Ohio will make final connection of service drop to customer conductors.
3. A two-pole non-fused sealable disconnect switch shall be installed and mounted no higher than 70" above the ground.
4. AES Ohio approved meter socket to be furnished and installed by customer. AES Ohio will furnish and install the meter.
5. Power supply to customer load per National Electric Code.
6. Customer equipment.
7. Service entrance per National Electric Code

NOTES:

- A. AES Ohio to specify the location and size of pole.

All items shown, except as indicated, to be supplied by customer.

Installation of customer antennas and other devices

Caution: Danger of electrocution

No customer antennas or other devices shall be connected to AES Ohio's lines, poles, crossarms, or other facilities. All antennas erected by the customer shall have a minimum clearance of eight feet from AES Ohio's nearest conductor and installed to avoid the possibility of the antenna falling into or making accidental contact with such conductors. The customer should avoid the erection of an antenna within close proximity to an electric line and should consult with AES Ohio in those cases where there is any question as to the clearance of the nearest electric line. The customer should also consult with local authorities concerning permits and regulations.



Electric construction

Section: Electric service handbook

Overhead services – Under 600V

Services may be attached to building in shaded areas only.

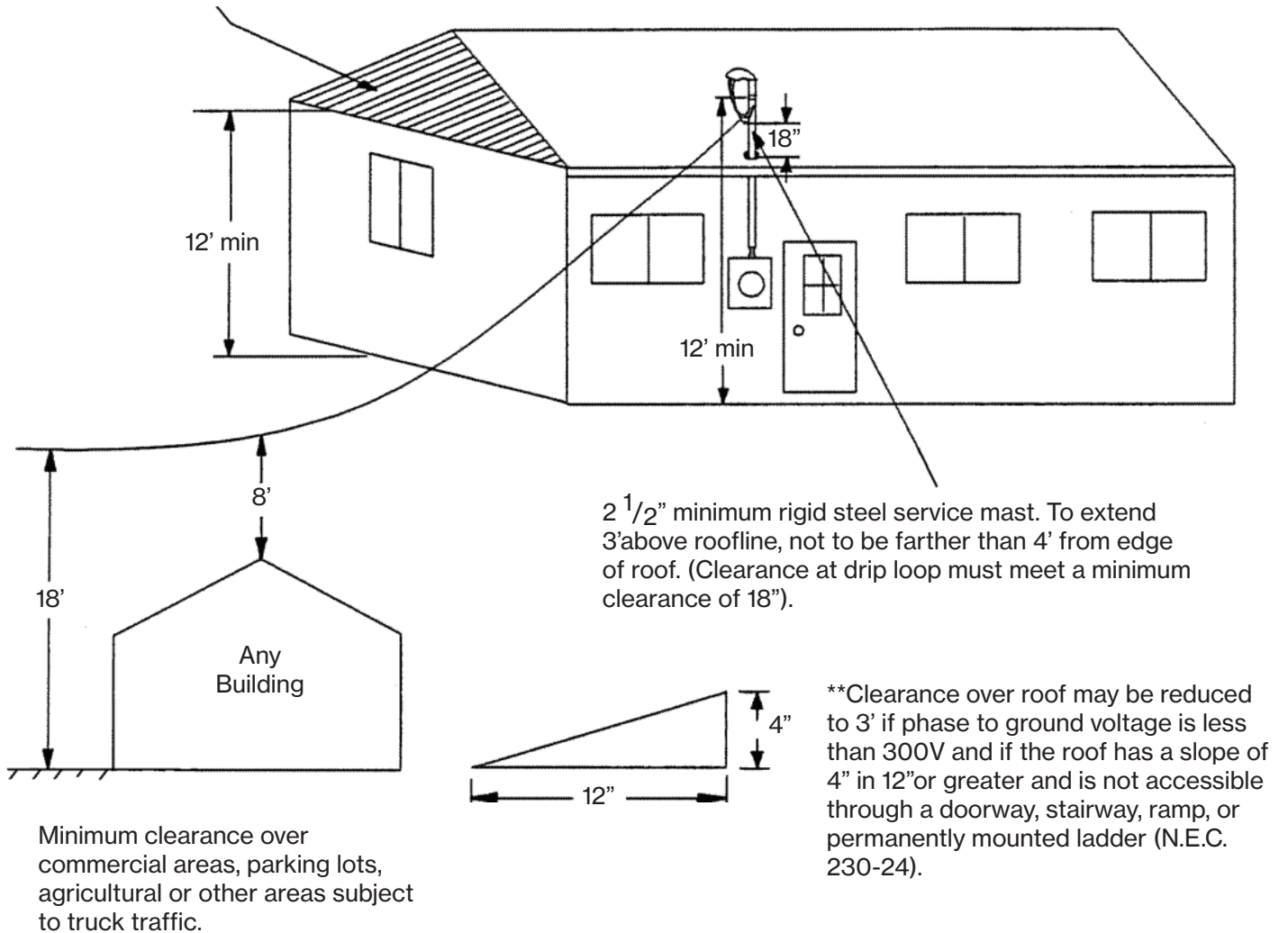

Note: All clearances shown are minimum clearances per N.E.C. for the service drop conductors. The sag in the service drop conductors must be considered when installing service attachment.

Electric construction

SH-08-003

Section: Electric service handbook

Overhead services – Under 600V

Maximum allowable mounting height for any service drop.

Services may be attached to building in shaded areas only.

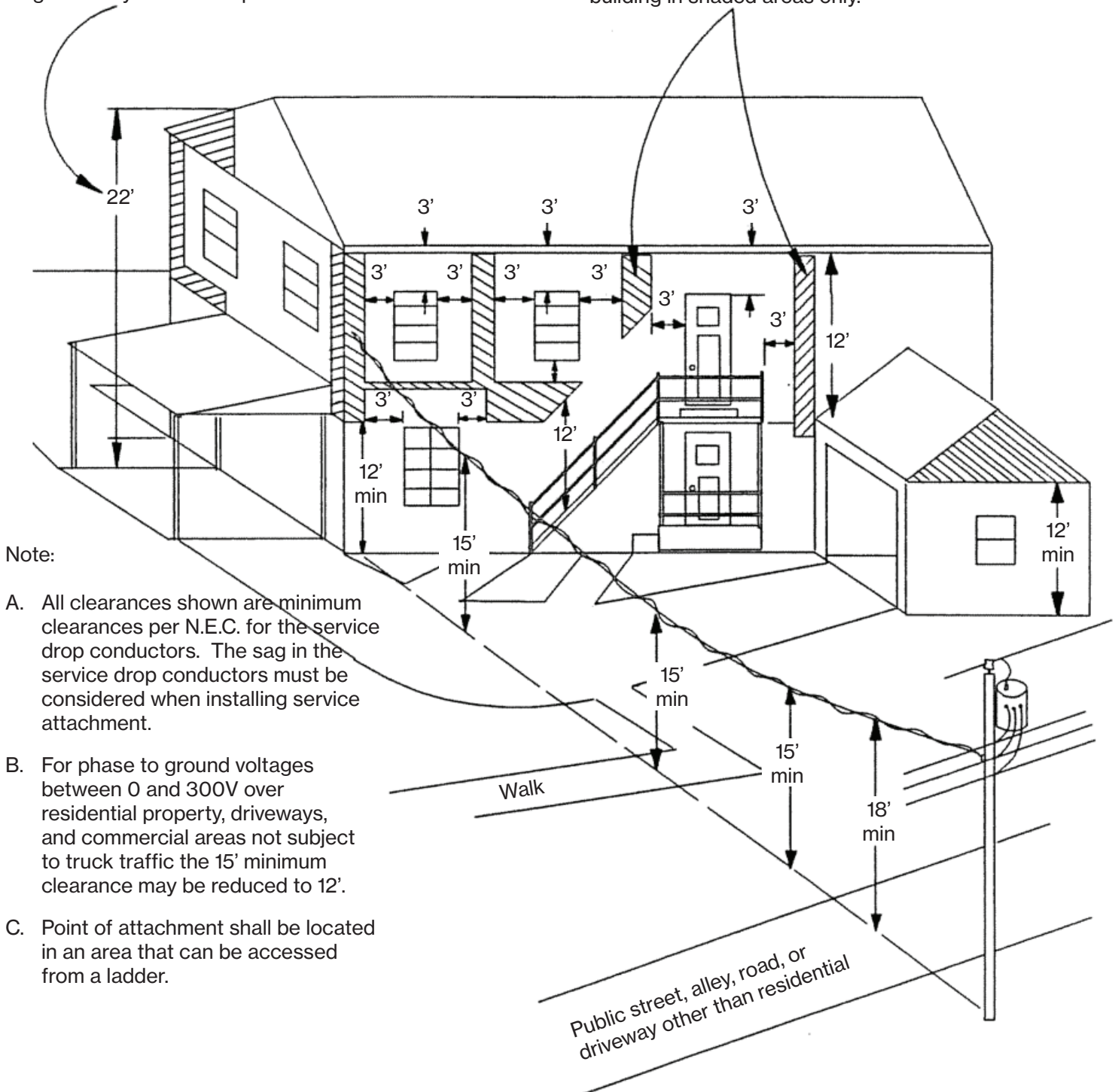

Electric construction

Section: Electric service handbook

Swimming pool clearances to open supply conductors

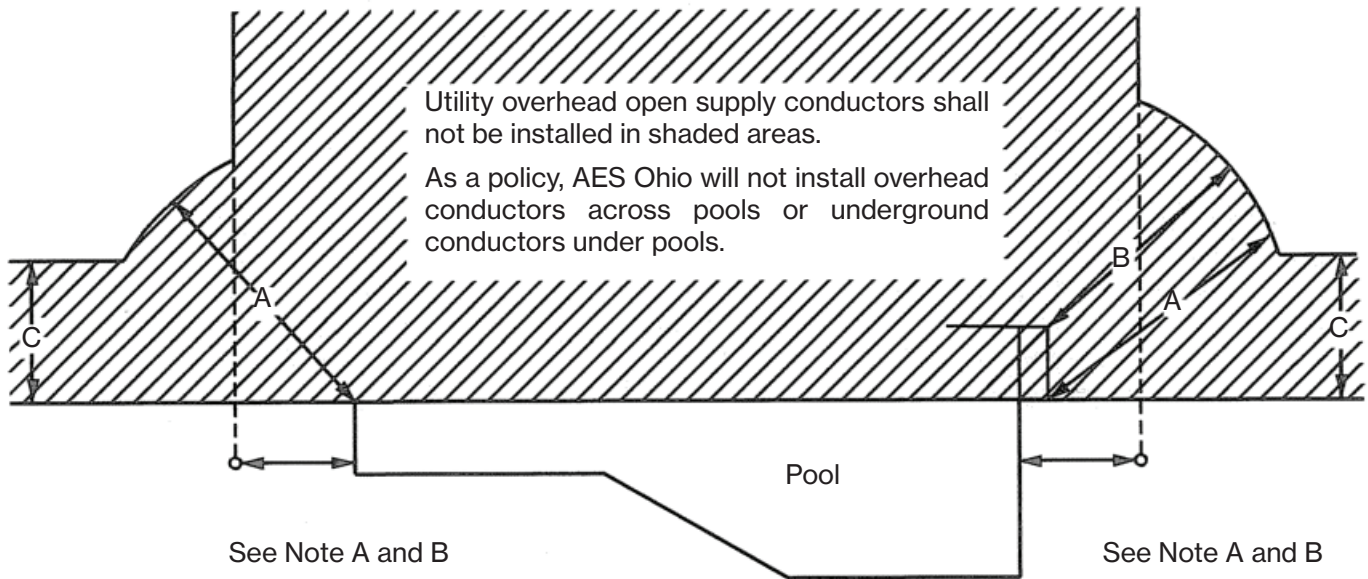

	CASE	* OPEN WIRE 0-750V	* OPEN WIRE AND CABLE 751V TO 50KV
A.	Clearance in any direction from the water level, edge of pool, base of diving platform, or anchored raft.	23 FT.	25 FT.
B.	Clearance in any direction to the diving platform or tower.	15 FT.	17 FT.
C.	Vertical clearance over adjacent land	National Electric Safety Code section 232	

(Voltages are Phase to Ground)

- These minimum clearances meet the NESC requirements.

Notes:

- Overhead open supply cables should not be installed over a swimming pool or in the area extending 10' beyond inside walls of the pool or its auxiliary equipment.
- Underground conductors less than 600 volts may be installed 10' beyond the outside walls of the pool.
- Local ordinances or rules may be more stringent than these requirements.

Electric construction

Section: Electric service handbook

Swimming pool clearances to triplexed cable

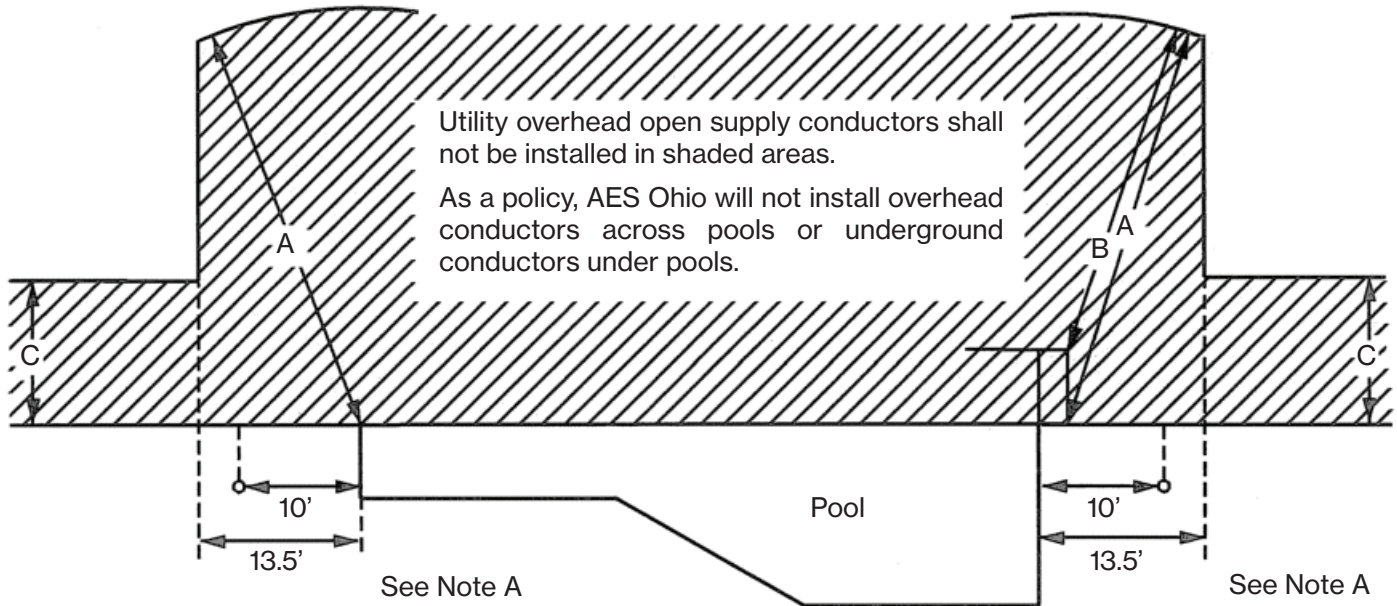

	CASE	* TRIPLEXED CABLE 0-300V GUY & MESSENGERS
A.	Clearance in any direction from the water level, edge of pool, base of diving platform, or anchored raft.	22.5 FT.
B.	Clearance in any direction to the diving platform or tower.	14.5 FT.
C.	Vertical clearance over adjacent land.	National Electric Safety Code Section 232

(Voltages are Phase to Ground)

*** These minimum clearances meet the NESC requirements.**

Notes:

- A. Overhead triplex supply cables shall not be installed over a swimming pool or in the area extending 10' beyond inside walls of the pool or its auxiliary equipment.
- B. Underground conductors less than 600 volts may be installed 10' beyond the outside walls of the pool.
- C. Overhead triplex supply cables that are 10' or more from the inside wall of the pool can be at NESC clearances over adjacent land.
- D. Local ordinances or rules may be more stringent than these requirements.

Electric construction

Section: Electric service handbook

Residential URD Secondary Service 400 Amp or Less

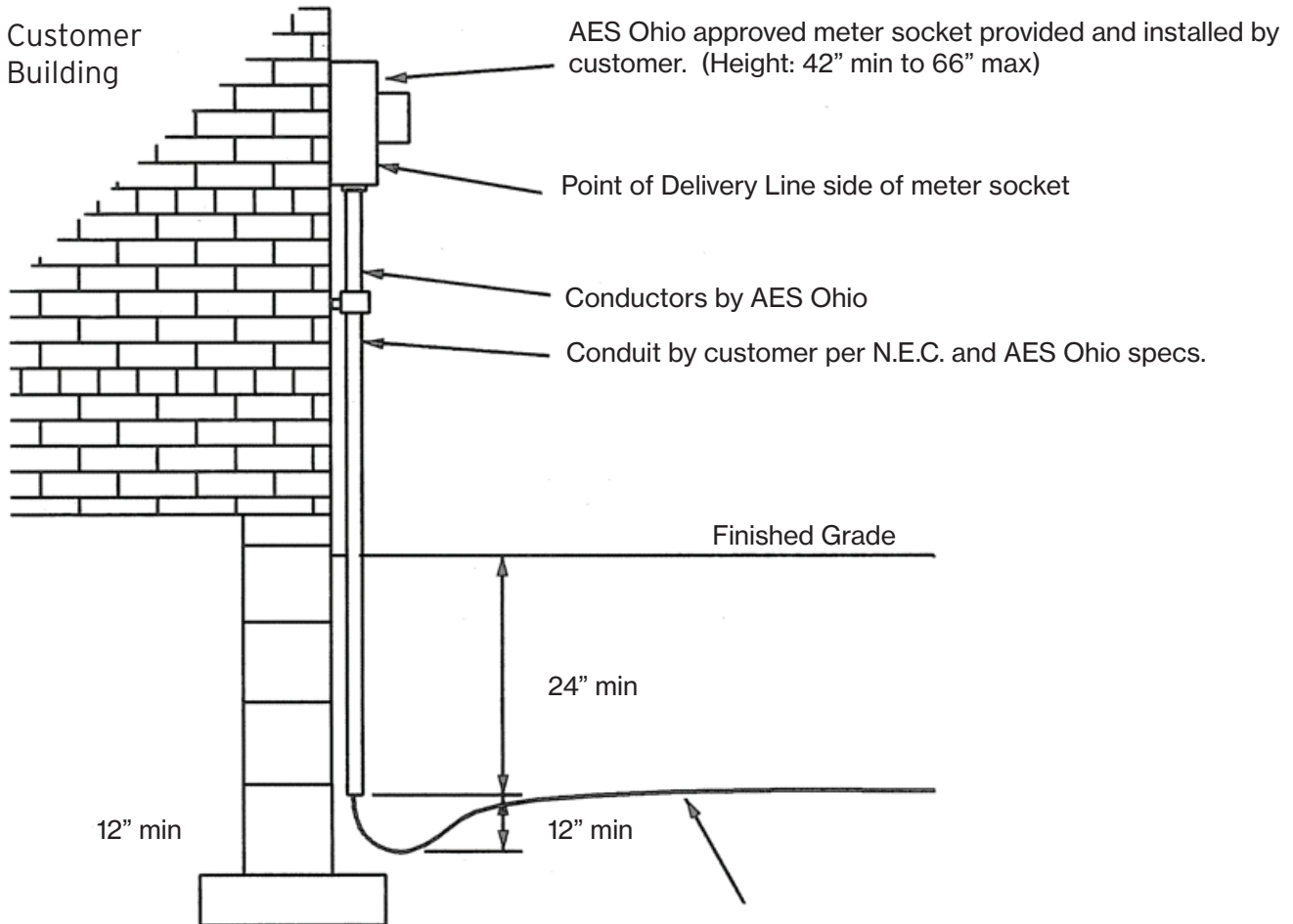

See Section 98 for installation requirements of secondary conductors. Trenching and backfilling by customer

Note:
The customer provides duct for AES Ohio conductors, if required. Under concrete, paved surfaces and decks.

Electric construction

Section: Electric service handbook

Residential URD secondary service greater than 400 amp

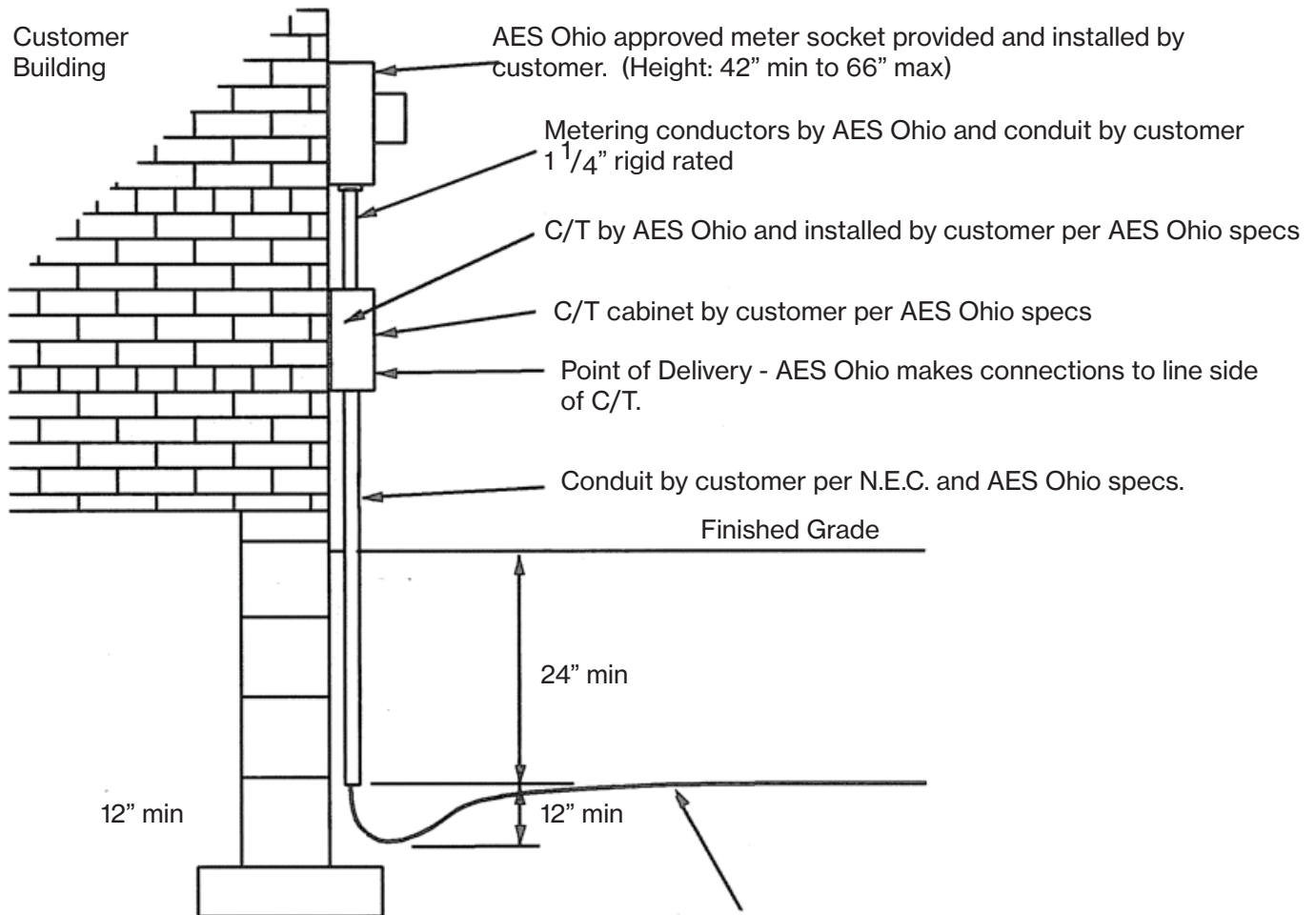

See Section 98 for installation requirements of secondary conductors

Note:

The customer provides duct for AES Ohio conductors, if required. Under concrete, paved surfaces and decks.

Contacts

aes-ohio.com/construction

Construction control center: 800-424-5578

Rev. March-21

Replaces: July-19

Report an outage:

877-468-8243

www.aes-ohio.com



Electric construction

SH-10-003

Section: Electric service handbook

Residential 400 AMP or less (1Ø, 3W, URD)

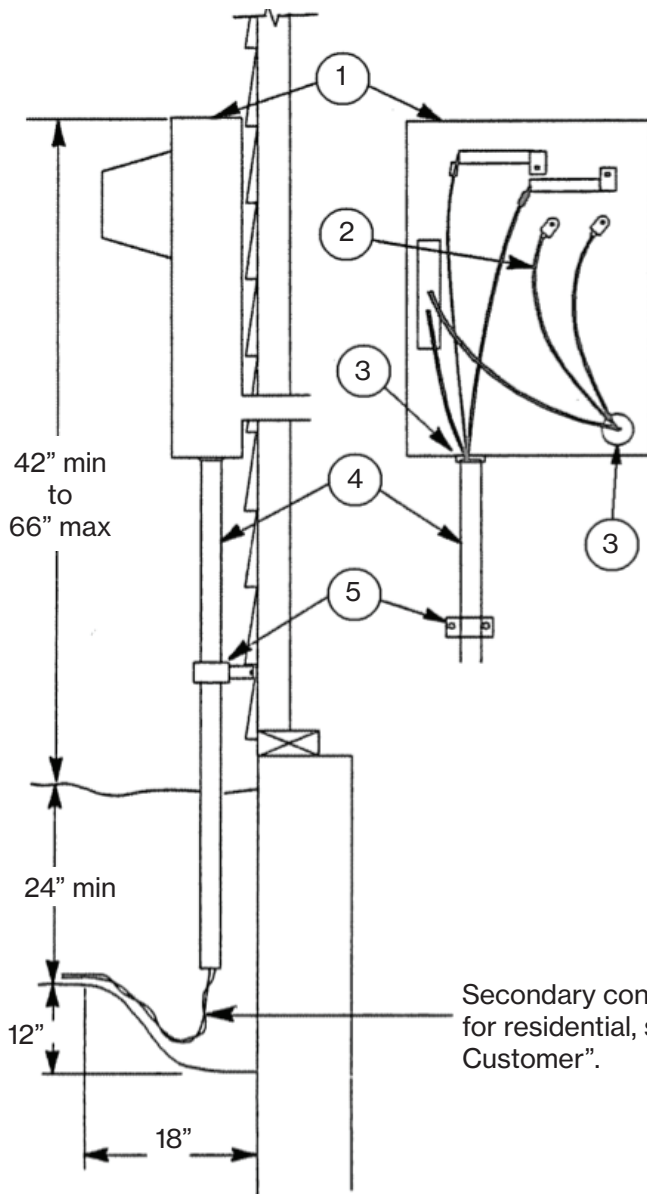

1. AES Ohio approved meter socket provided and installed by customer.
2. Customer conductors, sized per N.E.C. to be determined by an electrician
3. Approved box connector per N.E.C.
4. 2 1/2" minimum rigid conduit or PVC per N.E.C. and AES Ohio specifications. The conduit shall be continuous without splices and installed by customer on the left side of the bottom of meter socket.
5. Pipe strap as per N.E.C.

Secondary conductor provided and installed by AES Ohio for residential, see Section 98, "Trenching and Backfilling by Customer".

Notes:

- A. 3" conduit or PVC required for services larger than 200 AMP.
- B. Incoming line side wires must be connected to high side of meter – not reversed.

Electric construction

SH-10-004

Section: Electric service handbook

200 AMP and Smaller (3Ø, 4W, WYE, URD)
(480V see note below)

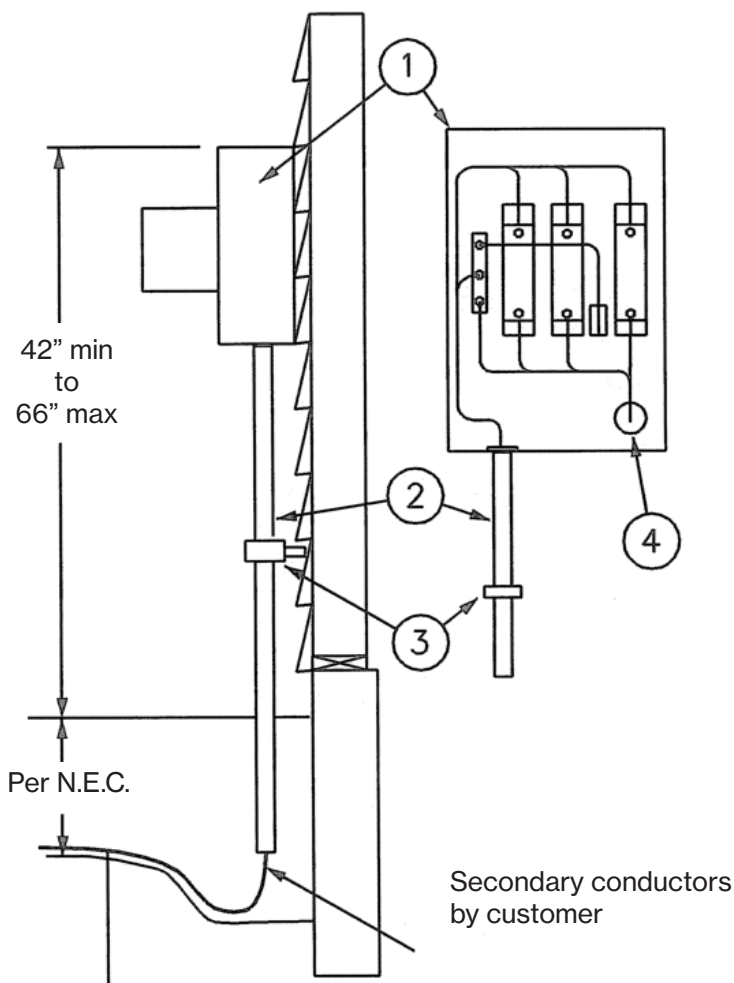

1. AES Ohio approved meter socket provided and installed by customer. Wire terminations by electrician
2. Customer provides and installs conduit per N.E.C.
3. Pipe straps as per N.E.C.
4. Box connector as per N.E.C

Note:

277/480 volt, 3-phase, WYE services require a load break "Sealed Utility Disconnect" on the line side of the meter socket

Contacts

aes-ohio.com/construction

Construction control center: 800-424-5578

Rev. March-21

Replaces: July-19

Report an outage:

877-468-8243

www.aes-ohio.com

aes Ohio

Electric construction

SH-10-005

Section: Electric service handbook

200 AMP and Smaller (3Ø, 4W, DELTA, URD)

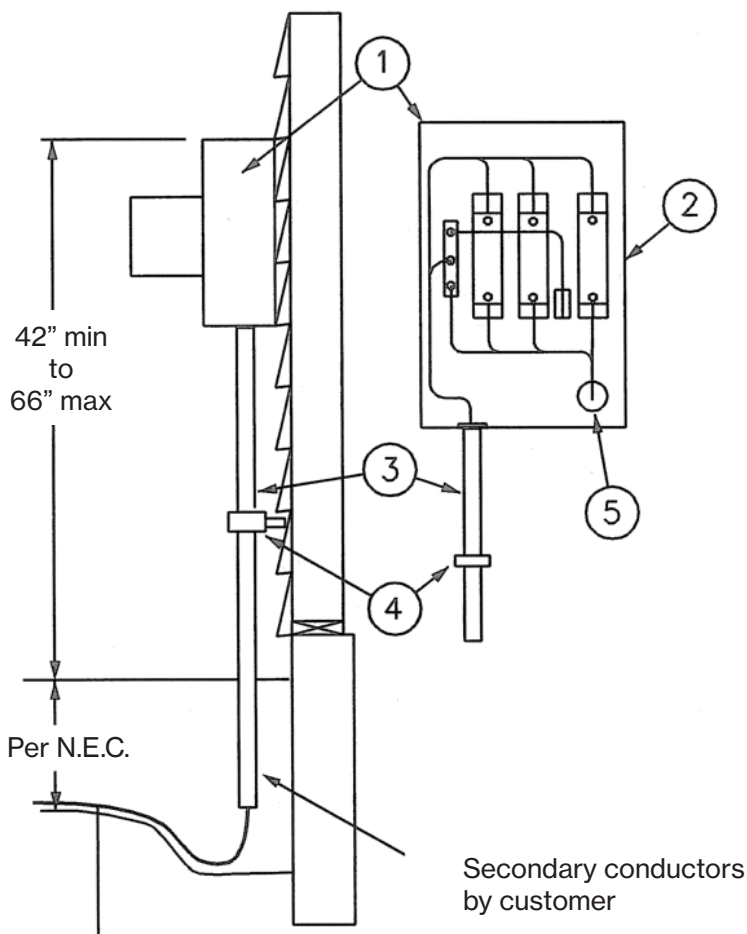

1. AES Ohio approved meter socket provided and installed by customer. Wire terminations by electrician.
2. High phase (208 volts to ground) to be identified orange and located on the right hand side terminal of meter socket.

Note: This same phase must be located in the center position of the main disconnect as per N.E.C.

3. Customer provides and installs conduit per N.E.C.
4. Pipe strap as per N.E.C.
5. Box connector as per N.E.C.

Note:

Due to way electric meter manufacturer configure the meter internally necessitates the High Phase (208 Volts to Ground) to be on the right-hand side of the meter socket.

Contacts

aes-ohio.com/construction

Construction control center: 800-424-5578

Rev. March-21

Replaces: July-19

Report an outage:

877-468-8243

www.aes-ohio.com

aes Ohio

Electric construction

SH-10-006

Section: Electric service handbook

401 to 1200 AMP with current transformer (1Ø, 3W, URD)

1. AES Ohio approved meter socket provided and installed by customer. The top of the meter socket must be mounted between a minimum of 42" and the maximum of 66" from final grade.
2. 1 1/4" rigid rated conduit per AES Ohio. All metal raceways to be bonded per NEC.
3. White polarity markings show the line side of CT.
4. Neutrals shall be tied together and bonded to the bottom of cabinet.
5. 3" minimum rigid conduit or PVC per N.E.C. and AES Ohio specifications. The conduit shall be continuous and installed by customer.
6. Grounding conductors as per N.E.C.
7. Current transformers furnished by AES Ohio and installed by customer. Current transformers shall be securely mounted to the 0.75" (3/4 inch) thick exterior grade wood backing board in the cabinet.
8. Services 800 amps and below 24" x 32" x 10" minimum C/T cabinet. Services greater than 800 amps 32" x 36" x 10" minimum C/T cabinet. Cabinet by the customer per AES Ohio specifications.
9. Secure conductor to 0.75" (3/4 inch) thick exterior grade wood backing board in the cabinet as needed.

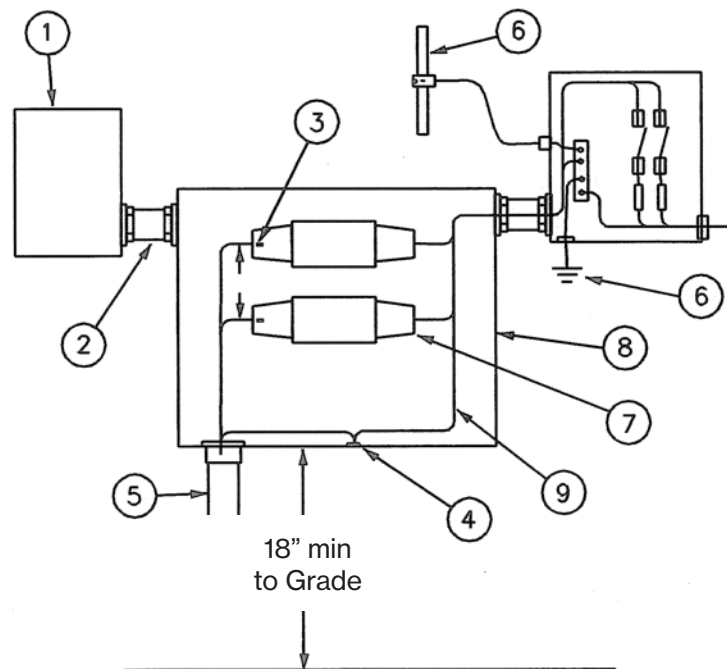

Note:
Number 5 does not apply to
commercial services.

Electric construction

SH-10-007

Section: Electric service handbook

201 to 1200 AMP with current transformer (3Ø, 4W, WYE, URD)

1. AES Ohio approved meter socket provided and installed by customer. The top of the meter socket must be mounted between a minimum of 42" and the maximum of 66" from final grade.
2. 1 1/4" rigid rated conduit per AES Ohio. All metal raceways to be bonded per NEC
3. White polarity markings show the line side of CT.
4. Neutrals shall be tied together and bonded to the bottom of cabinet.
5. Conduit per N.E.C.
6. Grounding conductors as per N.E.C.
7. Current transformers furnished by AES Ohio and installed by the customer. Current transformer shall be securely mounted to the 0.75" (3/4 inch) thick exterior grade wood backing board in the cabinet.
8. For services below 800 amps 32" X 36" X 10" minimum C/T cabinet. For services equal to or greater than 800 amps 48" x 48" x 12" minimum C/T cabinet. Cabinet by the customer per AES Ohio specifications.
9. Secure conductor to 0.75" (3/4 inch) thick exterior grade wood backing board in the cabinet as needed.

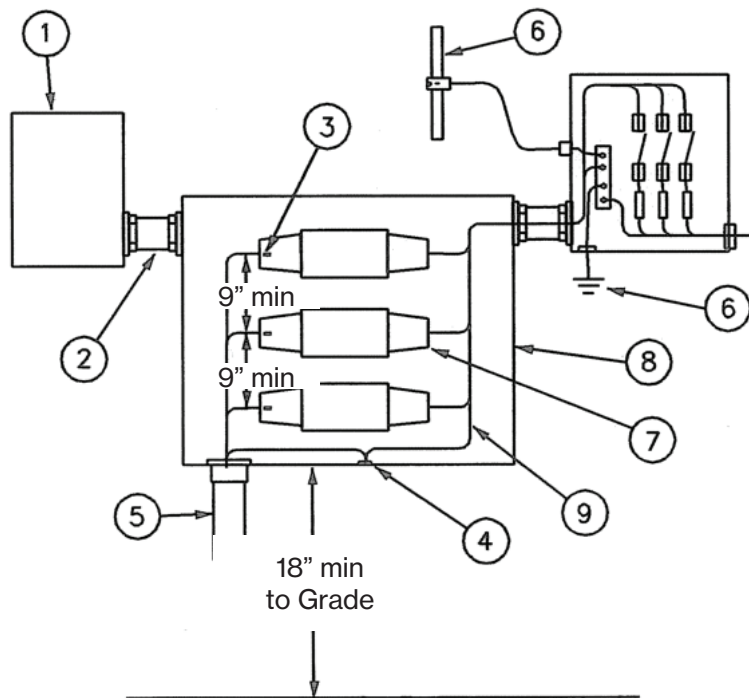

Secondary conductors
by customer

Electric construction

SH-10-009

Section: Electric service handbook

Pad Mounted transformer 1Ø self-contained commercial meter installation 400 Amp or less

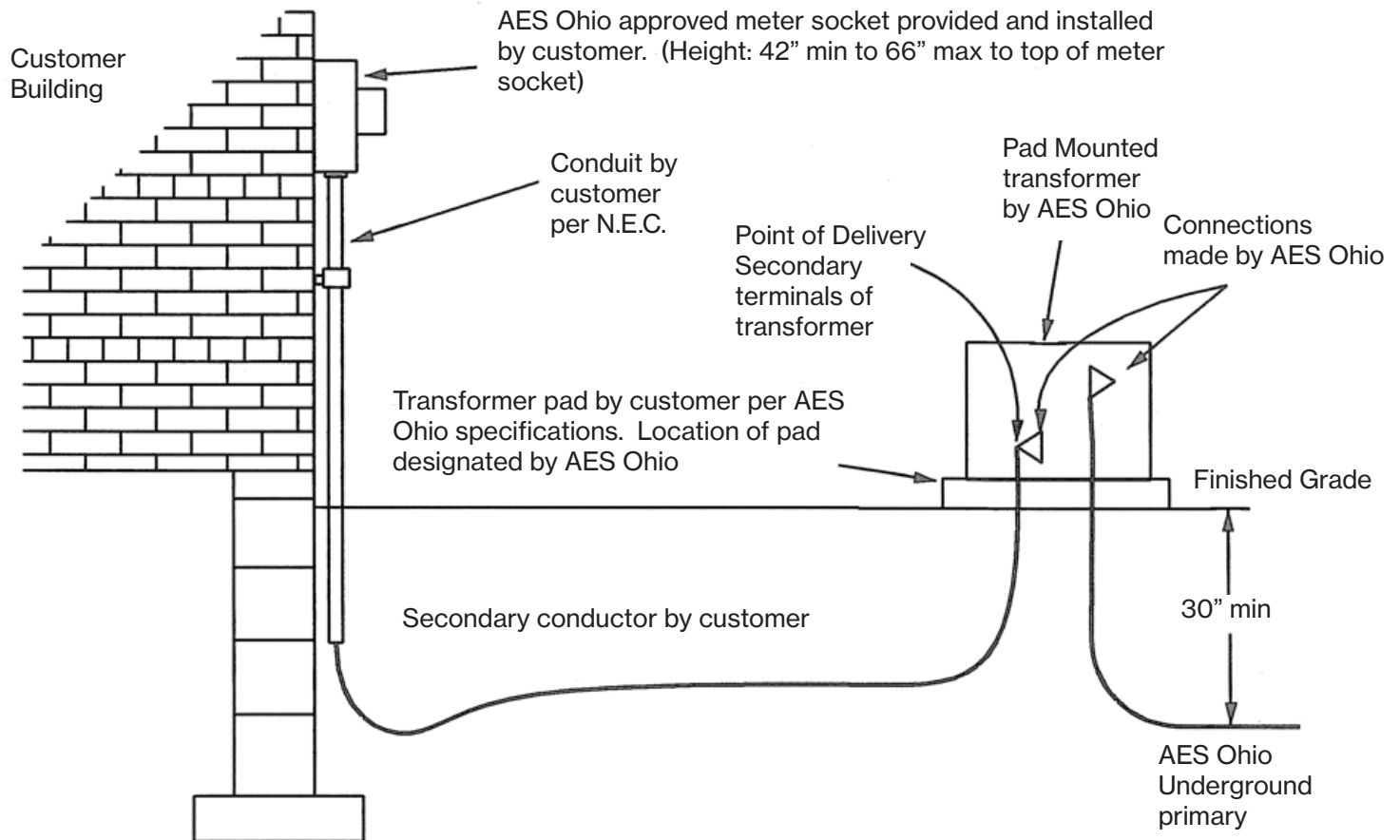

Notes:

- A. The customer provides all conduit required by AES Ohio on customer's property.
- B. AES Ohio may require a padmounted splice box to accommodate multiple conductors.

Electric construction

SH-10-010

Section: Electric service handbook

Pad mounted transformer service multiple meter commercial installation

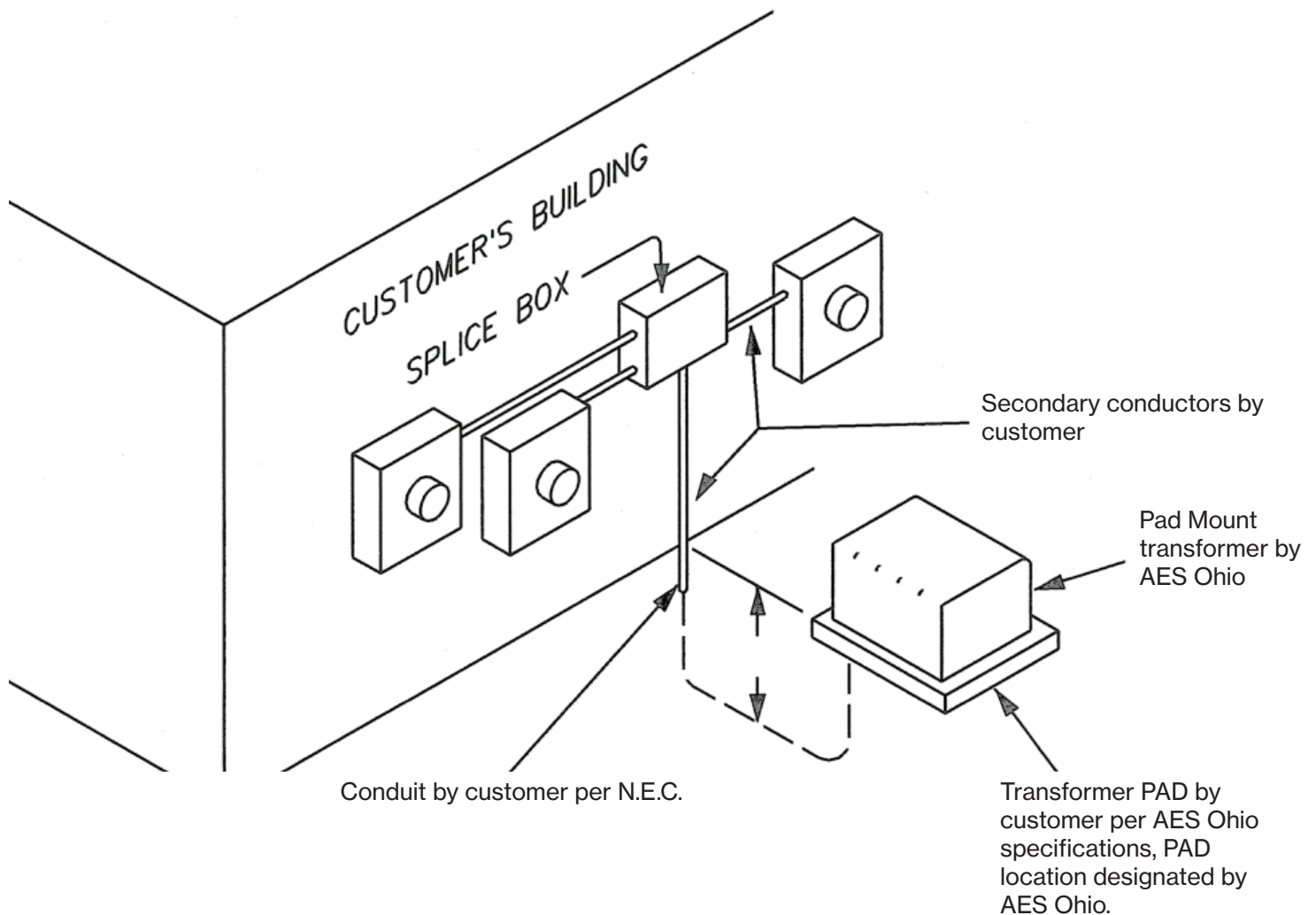

Notes:

- A. The customer provides all ducts, required by AES Ohio on customer's property.
- B. The number of conductors required to serve the building may dictate the use of a splice box mounted on the transformer pad. Consult AES Ohio as to when a pad mounted splice box is required.
- C. Height from top of meter box to ground shall be 42" (min) to 66" (max).
- D. CT cabinets may be required based on service size.

Contacts

aes-ohio.com/construction

Construction control center: 800-424-5578

Rev. March-21

Replaces: July-19

Report an outage:

877-468-8243

www.aes-ohio.com

aes Ohio

Electric construction

SH-10-011

Section: Electric service handbook

Commercial pad-mounted transformer service with a pad mounted metering cabinet on pad

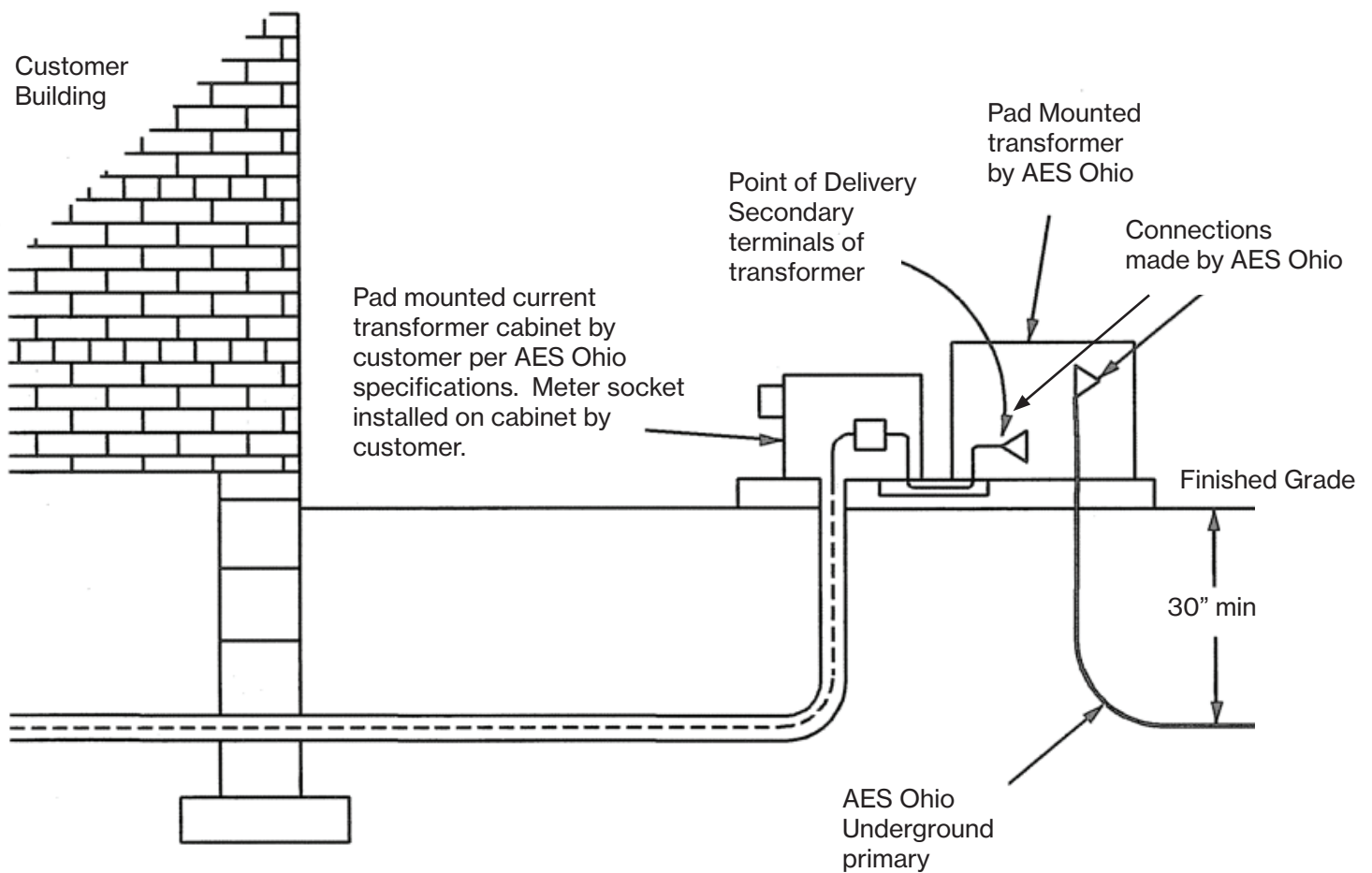

Notes:

- A. The customer provides all ducts required by for AES Ohio on customer's property.
- B. Height from top of meter box to ground shall be 42" (min) to 66" (max).
- C. Contact Meter Department on Meter Cabinet Approval.

Electric construction

Section: Electric service handbook

Conduit and Trenching Secondary Cable Routing Residential Services

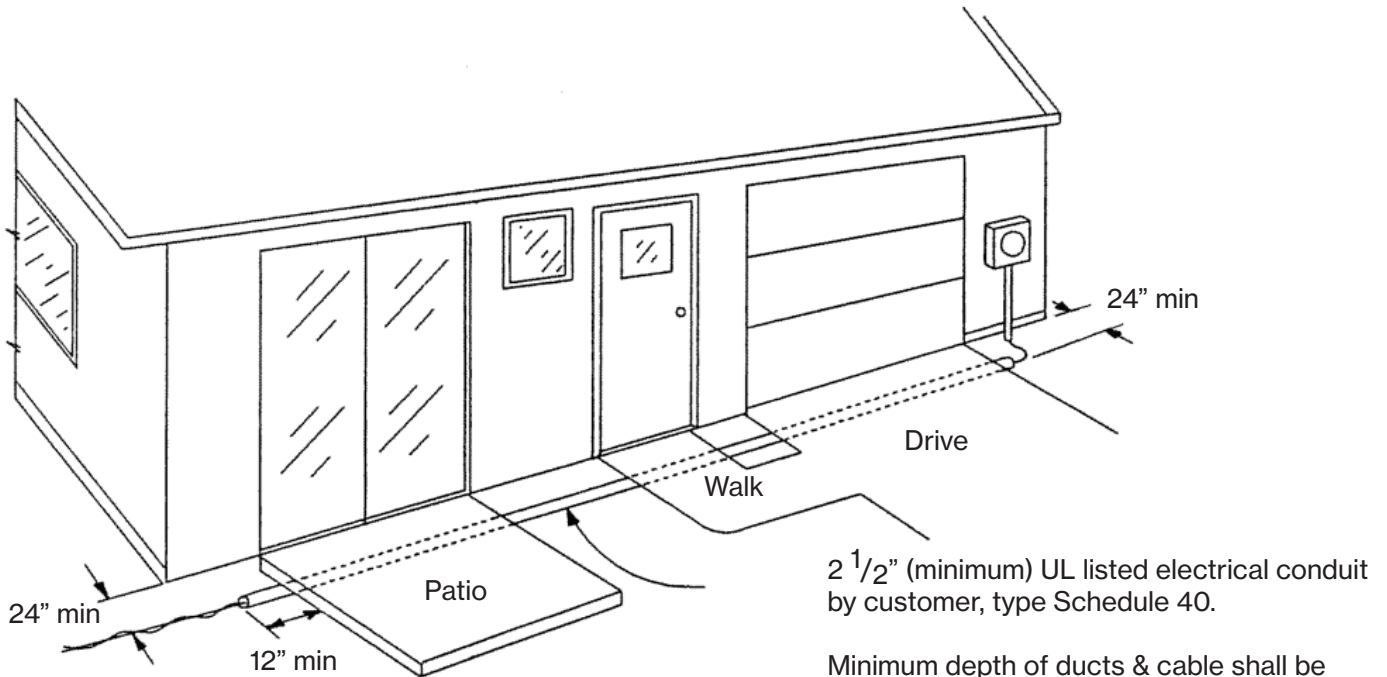

Customer to provide and install meter socket.

Minimum depth of ducts & cable shall be adequate to provide 24" minimum cover at final grade.

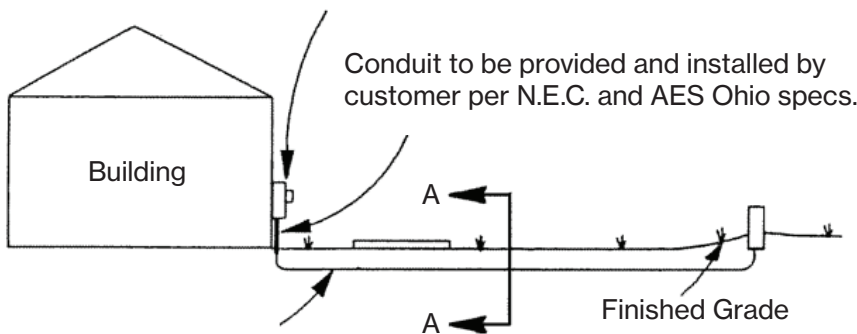

Transformer PAD by customer per AES Ohio specifications, PAD location designated by AES Ohio.

AES Ohio to furnish and install secondary conductors for residential. See Section 98 for installation requirements. Customer to trench and backfill. First 4" of backfill to be loose soil or sand, no large stones or sharp objects.

Section "A - A"

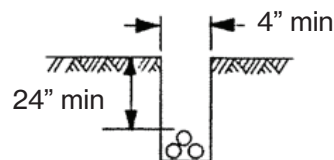

Electric construction

SH-10-013

Section: Electric service handbook

URD temporary service (1Ø, 3W)

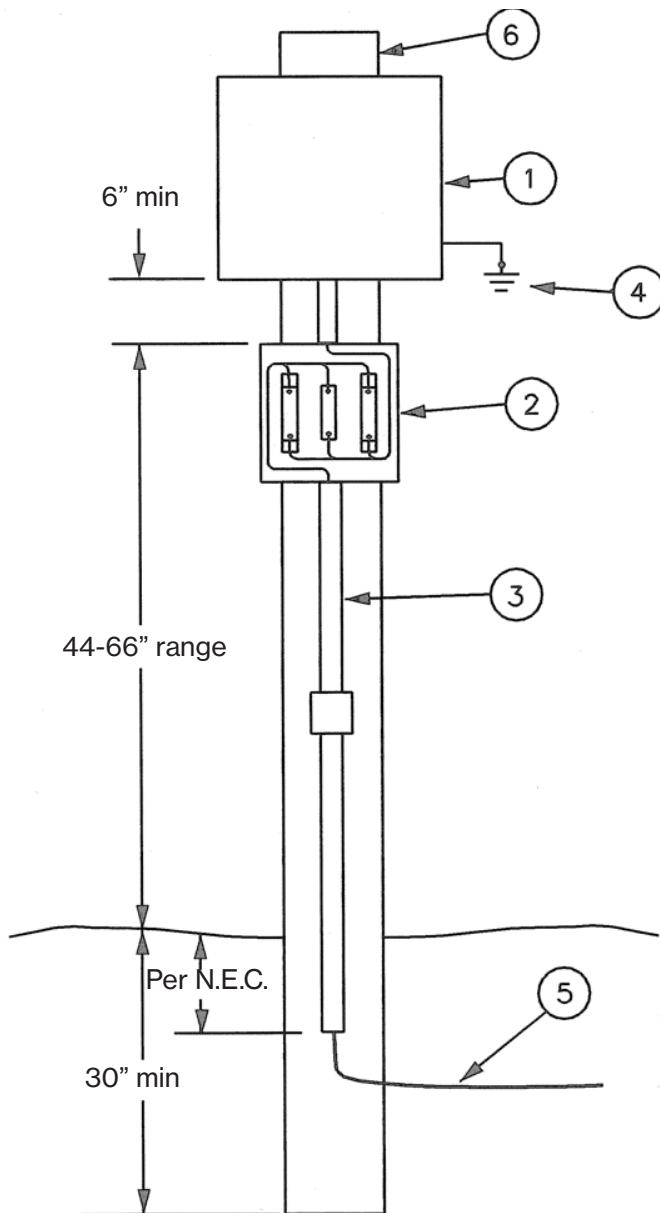

Items Controlled by Local Inspection Authority per N.E.C.

1. Customer Service switch /panel.
2. AES Ohio approved meter socket supplied and installed by customer
3. Conduit
4. Grounding Conductor
5. Conductors supplied and installed by customer

Items Controlled by AES Ohio

6. 4 x 4 wood post by customer. Set 30" deep minimum. Provided by customer.

Notes:

- A. Trench must be within 2' of AES Ohio service device. Leave 2' of conductor past the service device for AES Ohio connection.
- B. If no service facilities exist, payment may be required to obtain temporary service. Call AES Ohio for details.

Contacts

aes-ohio.com/construction

Construction control center: 800-424-5578

Rev. March-21

Replaces: July-19

Report an outage:

877-468-8243

www.aes-ohio.com

aes Ohio

Electric construction

SH-10-014

Section: Electric service handbook

1Ø Residential 400 Amp and smaller free standing and trailer installation – URD

1. AES Ohio approved meter socket provided and installed by customer.
2. Exterior grade lumber by customer.
3. All metal raceways to be bonded per N.E.C.
4. Conduit to extend 24" below grade per N.E.C. and AES Ohio specifications.
5. 4" x 4" treated post by customer.
6. Main disconnect switch provided and installed by customer.
7. Conduit per N.E.C. provided and installed by customer.
8. Grounding conductor per N.E.C.
9. Power supply per N.E.C.

Notes:

- A. Bottom of panels above grade per N.E.C.
- B. Customer to provide approved trench from AES Ohio facilities to metering point.
- C. Meter pedestals must be approved by AES Ohio Standards Department.

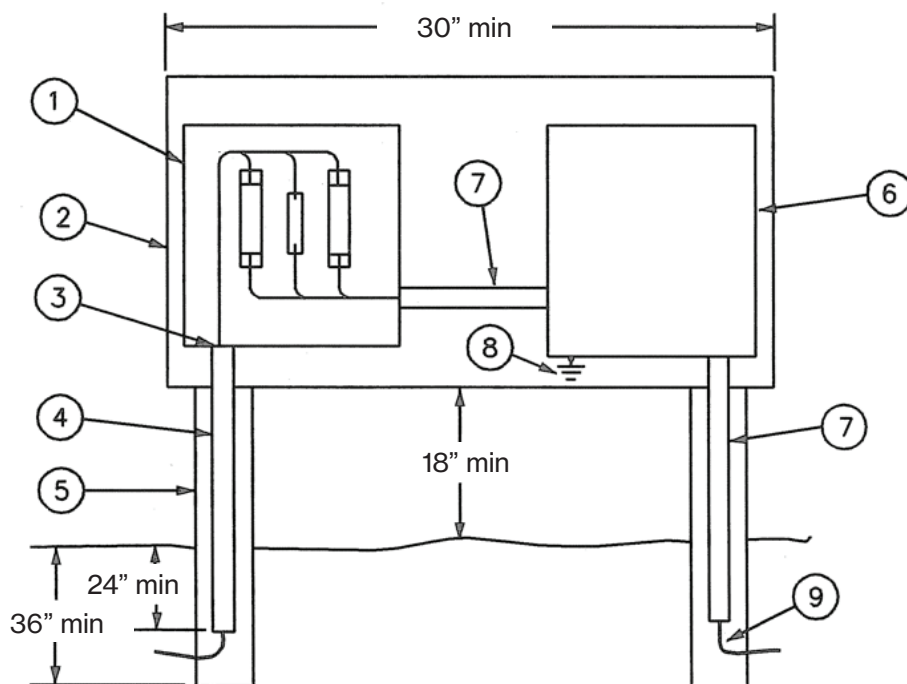

Contacts

aes-ohio.com/construction

Construction control center: 800-424-5578

Rev. March-21

Replaces: July-19

Report an outage:

877-468-8243

www.aes-ohio.com

aes Ohio

1Ø Commercial 100 AMP and smaller street lighting installation

Two metering options:

Option 1: Free Standing

1. AES Ohio approved meter socket provided and installed by the customer.
2. Exterior grade lumber, minimum $\frac{3}{4}$ " thick, or Unistrut provided and installed by customer.
3. All metal raceways to be bonded per N.E.C.
4. Conduit to extend 24" below grade per N.E.C. and AES Ohio specifications.
5. Two 4" x 4" exterior grade posts or Unistrut posts that are 36" below grade in 24" of cement provided and installed by customer.
6. Conduit per N.E.C. provided and installed by customer.
7. Grounding conductor per N.E.C. and installed by customer.
8. Power supply per N.E.C. and installed by customer.

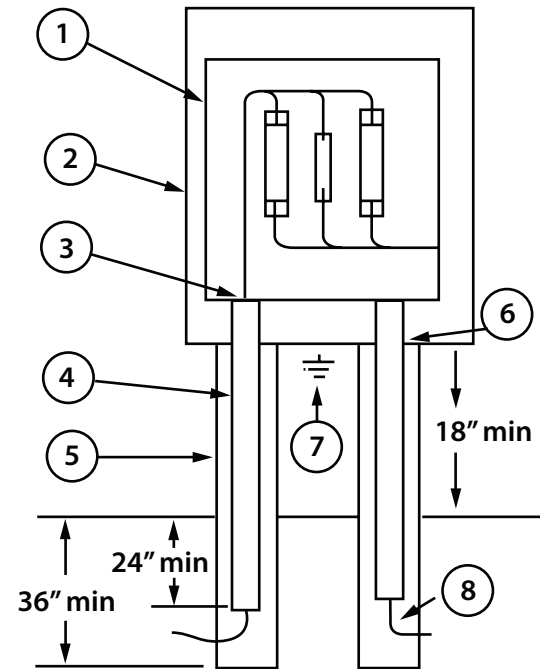

Option 2: Pedestal

1. AES Ohio approved meter pedestal provided and installed by the customer.
2. Pedestal must be secured to a 4" x 4" exterior grade post or Unistrut that is 36" below grade in 24" of cement.
3. Grounding conductor per N.E.C. and installed by customer.
4. Power supply per N.E.C. and installed by customer.

Notes:

- A. Meter must be no closer than 7' from AES Ohio facilities.
- B. Customer to provide approved trench from AES Ohio facilities to metering point.

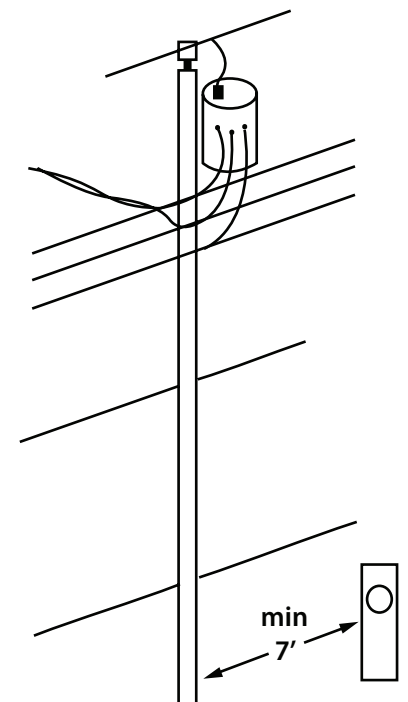

Contacts

aes-ohio.com/construction

Construction control center: 800-424-5578

Rev. March-21

Replaces: July-19

Report an outage:

877-468-8243

www.aes-ohio.com

aes Ohio

Electric construction

SH-11-001

Section: Electric service handbook

200 AMP and smaller (1Ø, 3W, OVHD W/O Mast)

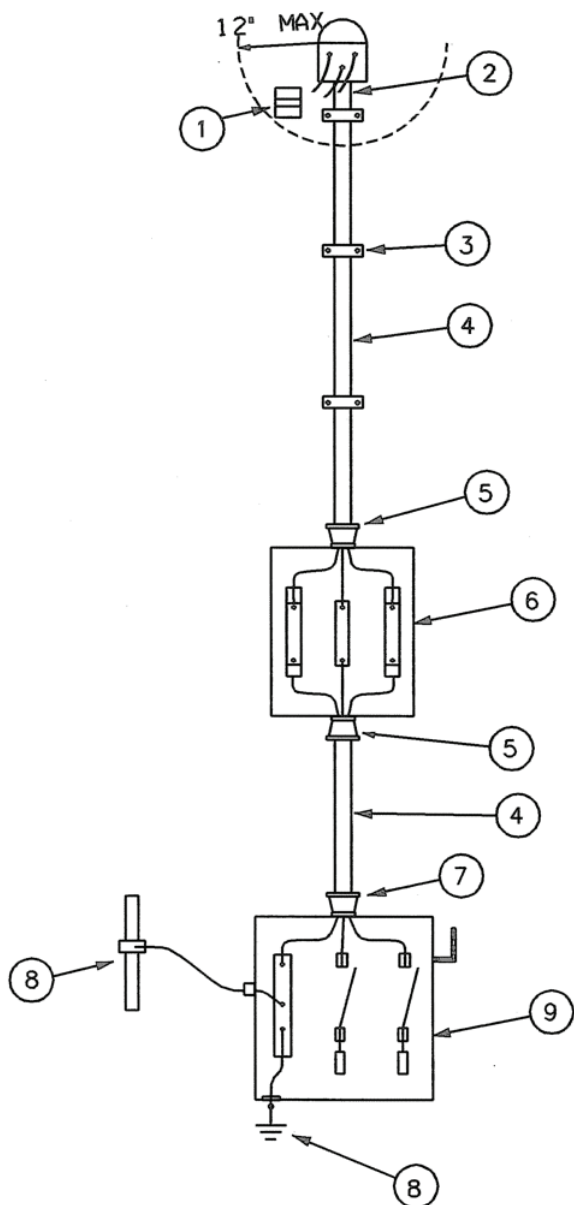

1. Clevis provided by AES Ohio and installed by customer in area shown.
2. Customer's conductors to extend 24" minimum beyond service head. AES Ohio to make connections to service drop.
3. Strap clamps per N.E.C.
4. Service conductor and conduit or service entrance cable per N.E.C.
5. Watertight connector.
6. AES Ohio approved meter socket provided and installed by customer. Wire terminations by electrician.
7. Approved box connector per N.E.C.
8. Grounding conductor as per N.E.C.
9. Customer disconnect per N.E.C.

Notes:

- A. All metal raceways to be bonded per N.E.C.
- B. Responsibility of the customer to install a clevis that provides proper overhead clearance over the surfaces traversed by the AES Ohio conductor.
- C. The meter shall be installed so that the top of the meter box will be between a height of 42" (min) to 66" (max) above the ground.

Contacts

aes-ohio.com/construction

Construction control center: 800-424-5578

Rev. March-21

Replaces: July-19

Report an outage:

877-468-8243

www.aes-ohio.com

aes Ohio

Electric construction

SH-11-002

Section: Electric service handbook

200 AMP and smaller (1Ø, 3W, OVHD with Mast)

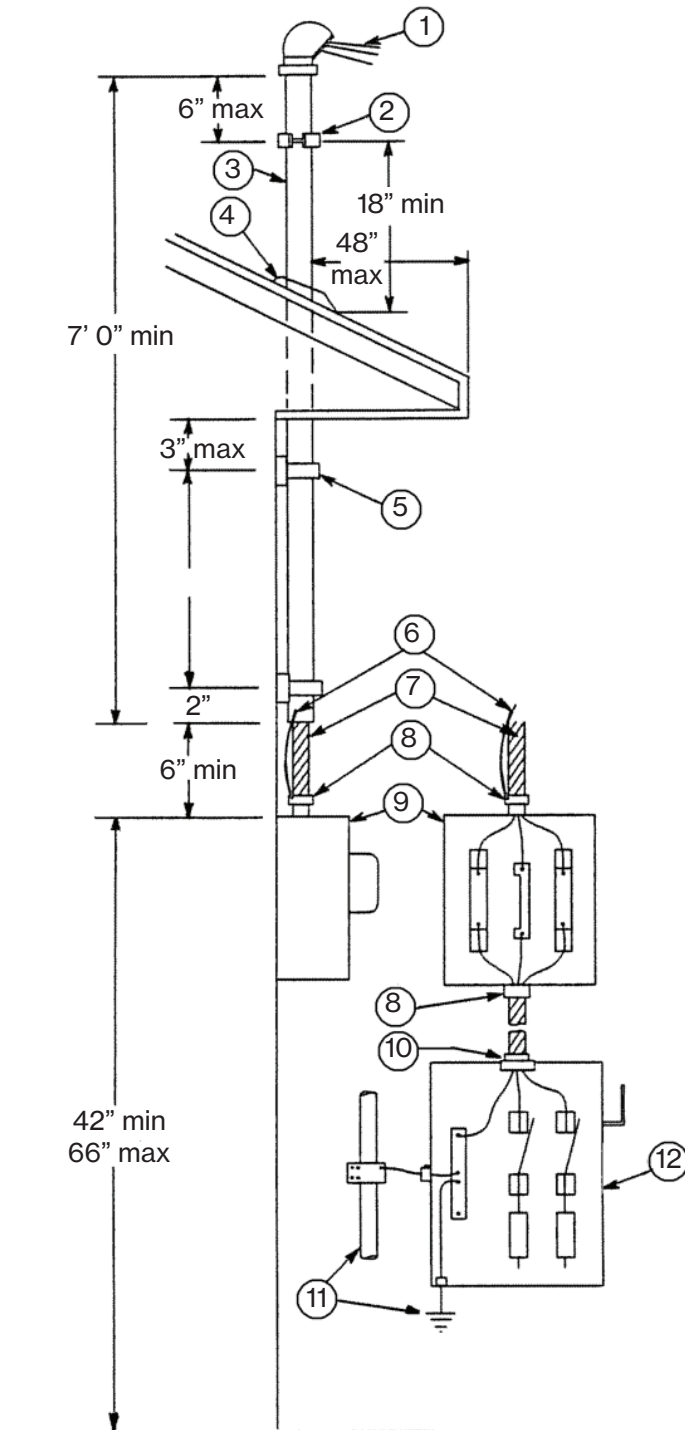

1. Customer's conductors shall extend 24" minimum beyond the service head. AES Ohio to make connections to service drop.
2. Bracket to be furnished and installed by customer.
3. 2 1/2" (minimum at installation) galvanized standard weight steel pipe. Continuous piping 7' minimum length. Note: Pipe supports must be bolted to the studs or support wall on new houses. Masts longer than 10 feet require AES Ohio approval. Service mast must be installed high enough to allow the service drop to meet minimum clearance of 12' at it's lowest sag point.
4. Roof shield for 2 1/2" conduit.
5. Split ring type pipe support. When attaching to concrete block, this point would be at the bottom of the second course from the top. On existing structures 1/2" x 3" min lag bolts may be substituted. 2 1/2" min lag bolt engagement in stud is required.
6. If mast is isolated, local inspection authorities may require it to be bonded.
7. Service entrance cable size per N.E.C.
8. Watertight connectors are required for the top, bottom, and sides as applicable.
9. AES Ohio approved meter socket provided and installed by customer. Wire terminations by electrician.
10. Box connector per N.E.C.
11. Grounding conductor as per N.E.C.
12. Customer disconnect per N.E.C.

Electric construction

SH-11-003

Section: Electric service handbook

200 AMP and smaller (3Ø, 4W, WYE OVHD)

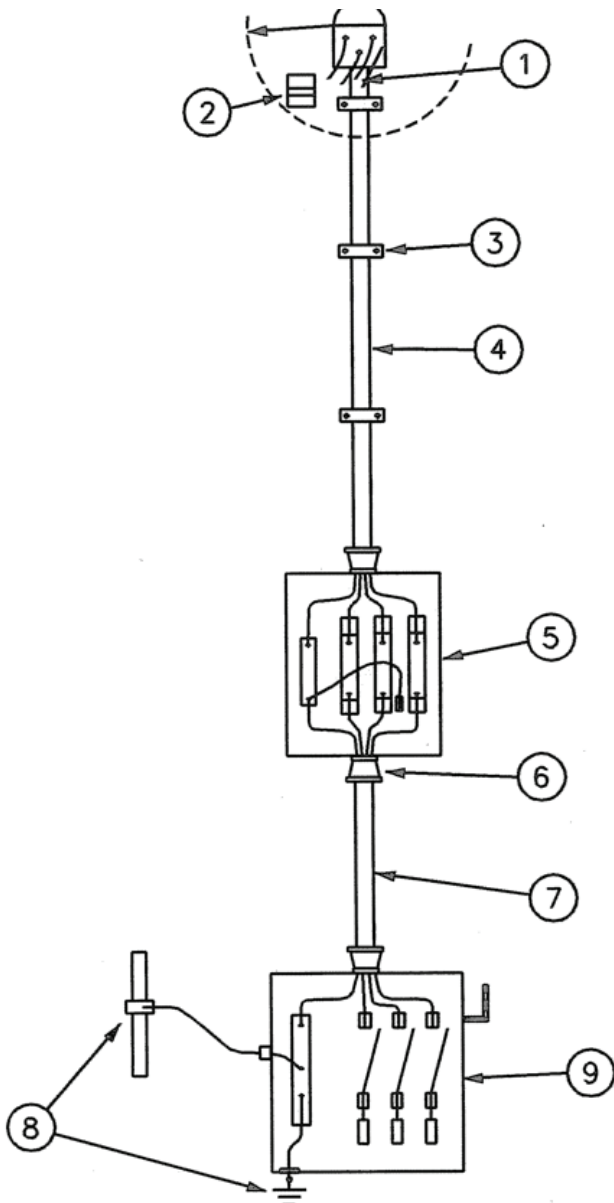

1. Customer's conductors to extend 24" minimum beyond service head. AES Ohio to make connections to service drop.
2. Clevis to be provided by AES Ohio and installed by customer in area shown.
3. Strap clamps as per N.E.C.
4. Conduit per N.E.C. provided by customer.
5. Meter socket provided and installed by customer. Wire terminations by electrician.
6. All bushings bonded when using metal conduit. Bonding conductors sized per N.E.C.
7. Conduit per N.E.C.
8. Grounding conductor as per N.E.C.
9. Customer disconnect per N.E.C.

Note:

The meter shall be installed so that the top of the meter box will be at a height of 42" (min) to 66" (max) above the ground.

Contacts

aes-ohio.com/construction

Construction control center: 800-424-5578

Rev. March-21

Replaces: July-19

Report an outage:

877-468-8243

www.aes-ohio.com

aes Ohio

200 AMP and smaller (3Ø, 4W, DELTA, OVHD)

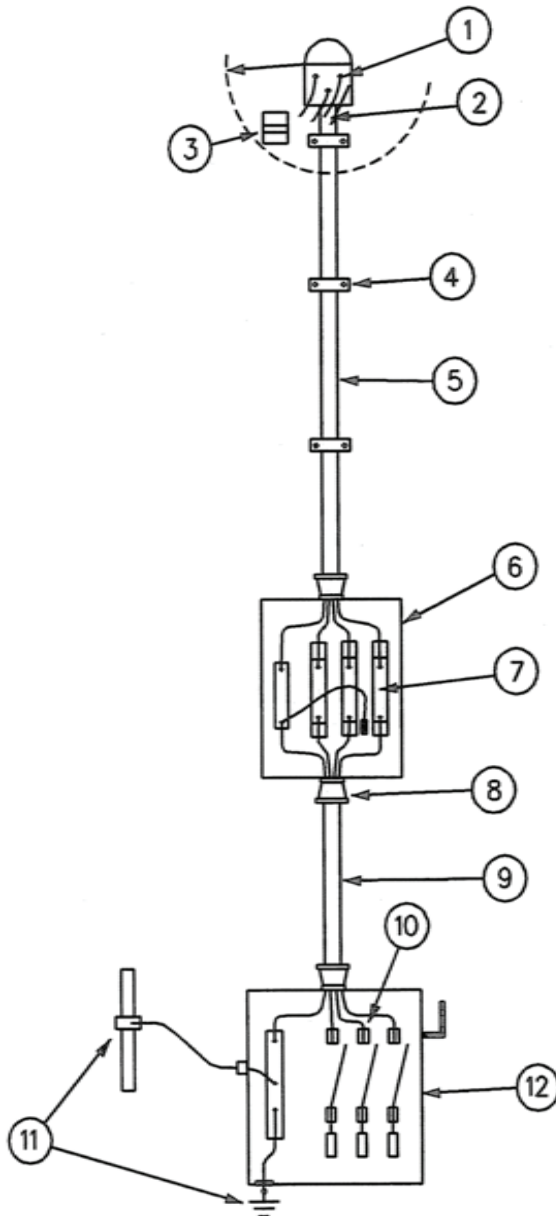

1. High phase (208 volts to ground) to be identified orange.
2. Customer's conductors to extend 24" minimum beyond service head. AES Ohio to make connections to service drop.
3. Clevis provided by AES Ohio and installed by customer in area shown.
4. Pipe straps per N.E.C.
5. Conduit per N.E.C. provided by customer.
6. AES Ohio approved meter socket provided and installed by customer. Wire terminations by electrician.
7. High phase identified orange. Must be on right hand terminal of meter socket.
8. All bushings bonded when using metal conduit. Bonding conductors sized per N.E.C.
9. Conduit per N.E.C.
10. High phase to be in center position as per N.E.C.
11. Grounding conductor as per N.E.C.
12. Customer disconnect per N.E.C.

Note:

The meter shall be installed so that the top of the meter box will be at a height of 42" (min) to 66" (max) above the ground.

Electric construction

SH-11-005

Section: Electric service handbook

401 to 1200 AMP current transformer service (1Ø, 3W, OVHD)

1. When used as a support mast, conduit must be 3" min., rigid galvanized steel. Conduit longer than 10 feet or with couplings requires AES Ohio approval.
2. AES Ohio approved meter socket provided and installed by customer. The top of the meter socket must be mounted between a minimum of 42" and the maximum of 66" from final grade.
3. 1 1/4" rigid rated conduit per AES Ohio. All metal raceways to be bonded per N.E.C.
4. White polarity marking (install as shown).
5. Neutrals shall be tied together through the bottom of cabinet.
6. Customer's conductors to extend 24" minimum beyond service head. AES Ohio to make connections to service drop.
7. Grounding conductor as per N.E.C.
8. Services 800 amps and below 24" x 32" x 10" minimum C/T cabinet. Services greater than 800 amps 32" x 36" x 10" minimum C/T cabinet. Cabinet by the customer per AES Ohio specifications.
9. Current transformers furnished by AES Ohio and installed by customer. Transformers shall be securely mounted to 0.75" (3/4 inch) thick exterior grade wood backing board in the cabinet.
10. Conductor secured to board as needed.
11. When used clevis supplied by AES Ohio and installed by customer.
12. Customer disconnect per N.E.C.

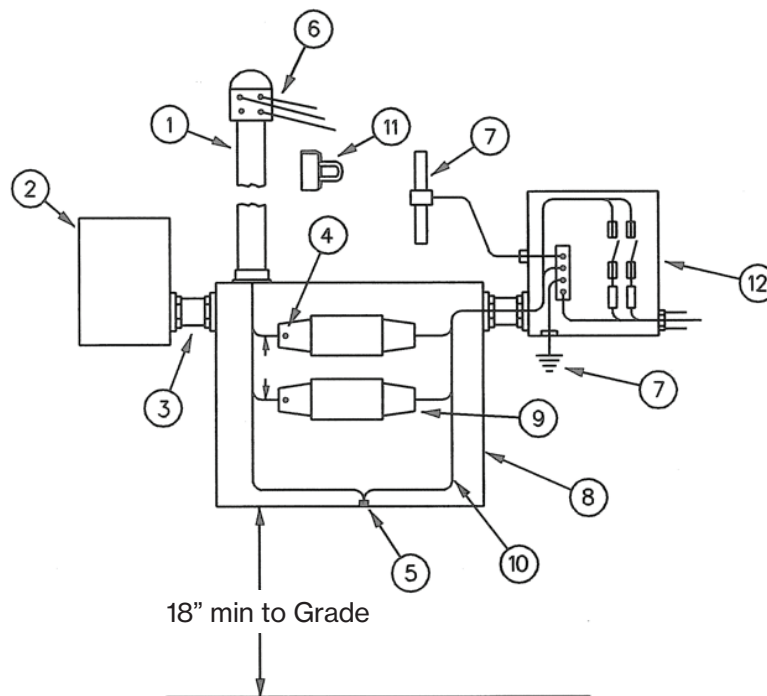

Electric construction

Section: Electric service handbook

201 to 1200 AMP current transformer service (3Ø, 4W, WYE, OVHD)

1. When used as a support mast, conduit must be 3" min., rigid galvanized steel. Conduit longer than 10 feet or with couplings requires AES Ohio approval.
2. AES Ohio approved meter enclosure provided and installed by customer. The top of the meter socket must be mounted between a minimum of 42" and the maximum of 66" from final grade.
3. 1 1/4" rigid rated conduit per AES Ohio. All metal raceways to be bonded per N.E.C.
4. White polarity marking (install as shown).
5. Neutrals shall be tied together through the bottom of cabinet.
6. Customer's conductors to extend 24" minimum beyond service head. AES Ohio to make connections to service drop.
7. Grounding conductor as per N.E.C.
8. Current transformers furnished by AES Ohio and installed by customer. Transformers shall be securely mounted to 0.75" (3/4 inch) thick exterior grade wood backing board in the cabinet.
9. For services below 800 amps 32" x 36" x 10" minimum C/T cabinet. For services equal to or greater than 800 amps 48" x 48" x 12" minimum C/T cabinet. Cabinet by the customer per AES Ohio specifications.
10. Conductor secured to board as needed.
11. When used, clevis supplied by AES Ohio and installed by customer.
12. Disconnect per N.E.C.

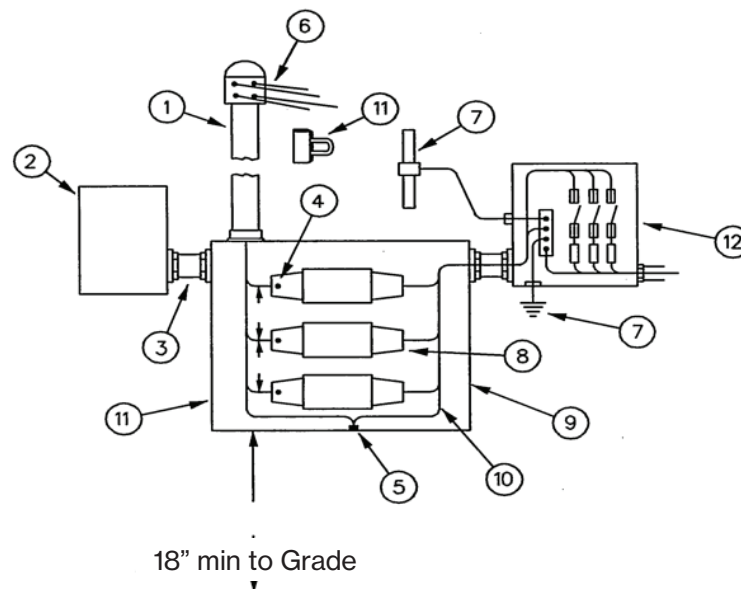

201 to 1200 AMP current transformer service (3Ø, 4W, DELTA, OVHD)

1. When used as a support mast, conduit must be 3" min., rigid galvanized steel. Conduit longer than 10 feet or with couplings requires AES Ohio approval.
2. AES Ohio approved meter enclosure provided and installed by customer. The top of the meter socket must be mounted between a minimum of 42" and the maximum of 66" from final grade.
3. 1 1/4" rigid rated conduit per AES Ohio. All metal raceways to be bonded per N.E.C.
4. White polarity marking (install as shown).
5. Neutrals shall be tied together through the bottom of cabinet.
6. High phase (208 volts to ground) to be identified orange.
7. Customer's conductors to extend 24" minimum beyond service head. AES Ohio to make connections to service drop.
8. High phase per N.E.C.
9. Grounding conductor as per N.E.C.
10. Current transformers furnished by AES Ohio and installed by customer. Transformers shall be securely mounted to 0.75" (3/4 inch) thick exterior grade wood backing board in the cabinet.
11. For services below 800 amps 32" x 36" x 10" minimum C/T cabinet. For services equal to or greater than 800 amps 48" x 48" x 12" minimum C/T cabinet. Cabinet by the customer per AES Ohio specifications.
12. High phase to be identified orange and located on bottom when CT's are mounted horizontally or on right when CT's are mounted vertically.
13. Conductors to be secured to 0.75" (3/4 inch) thick exterior grade wood backing board in the cabinet as needed.
14. When used, clevis supplied by AES Ohio and installed by customer.
15. Disconnect per N.E.C.

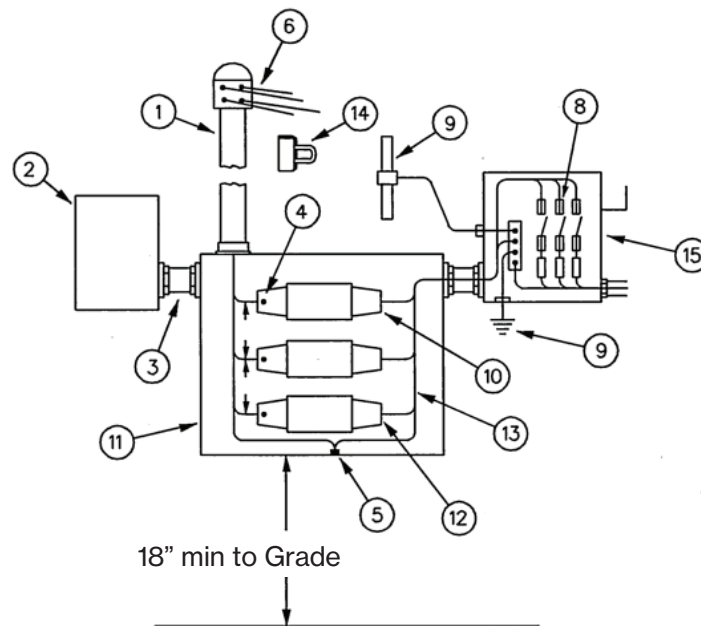

120V overhead service

120 volt, 1 phase, 2 wire service entrance and meter installation, using service entrance

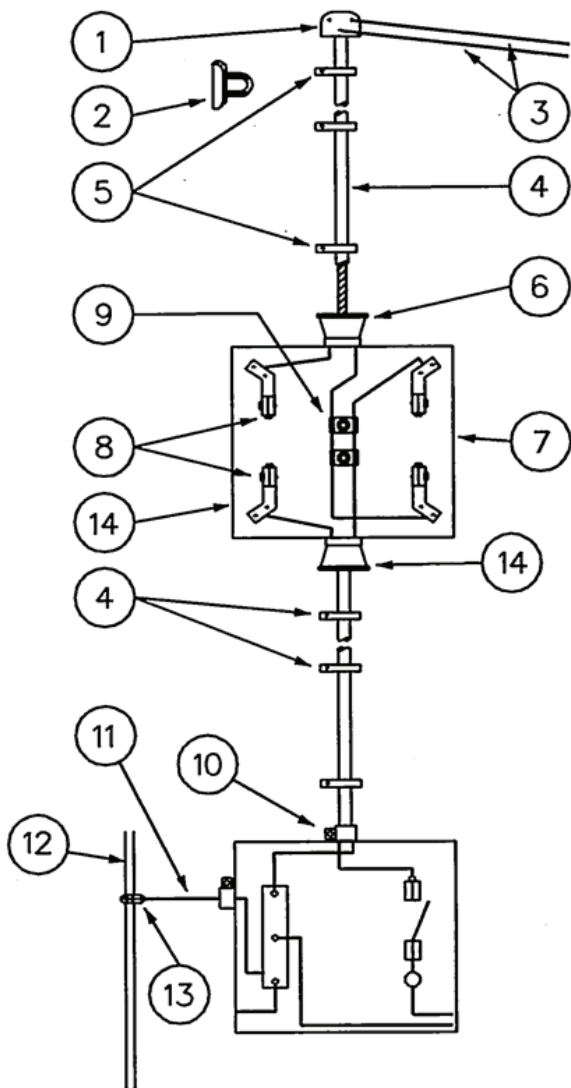

1. Weatherhead
2. When used clevis supplied by AES Ohio and installed by customer.
3. Customer's conductors shall extend 24" minimum beyond the weatherhead. AES Ohio to make connections to service drop.
4. Service-entrance cable per N.E.C.
5. Service cable straps per N.E.C.
6. Water-tight connector, of the rubber grommet type, with 1 1/4" threads.
7. Meter socket with 1 1/4" threaded hub in top.
8. Socket jaws.
9. Neutral lugs. Neutral conductors shall be continuous through neutral lugs, as shown.
10. Box connector.
11. Grounding conductor as per N.E.C.
12. Grounding electrode as per N.E.C.
13. Ground clamp per N.E.C.
14. If service entrance cable and water tight are not used, a conduit nipple may be used between meter socket and service equipment. Nipple shall be not less than 1" by 5" and shall be bonded to cabinet. Arrangement of socket wiring shall be as shown

Note:

AES Ohio approved meter sockets shall be furnished and installed by customer in an accessible location. The top of the meter socket must be mounted between a minimum of 42" and the maximum of 66" from final grade. Sockets shall be securely mounted with screws and must be plumb, with the socket jaws vertical, as shown. Location of sockets is subject to AES Ohio approval.

Overhead temporary service

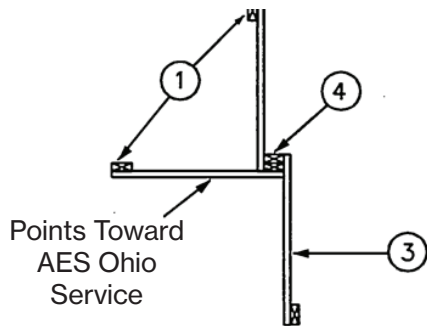

Top View

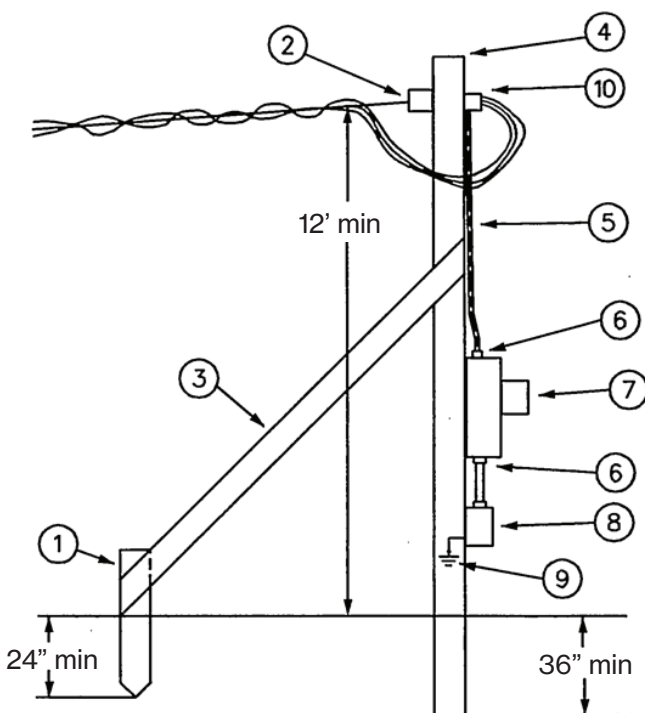

Side View

1. 2"x 4" stakes driven either vertically or in line with brace for a minimum of 24" into the ground.
2. Clevis provided by AES Ohio and installed by customer.
3. 3 - 2" x 4" braces (see top view)
4. Temporary service pole (two 2 x 6's joined together or 4' x 4' min. 16' long) provided and installed by customer. Braces will be required on all temporary poles. Location and height of pole to be specified by AES Ohio engineering department.
5. Service entrance cable by customer sized per N.E.C. to extend 24" minimum beyond the service head. AES Ohio to make connections to service drop.
6. Watertight connector.
7. AES Ohio approved meter socket provided and installed by customer. (From top of meter to ground 42" min to 66" max)
8. Main disconnect switch by customer.
9. Grounding conductor as per N.E.C.

Overhead trailer installation

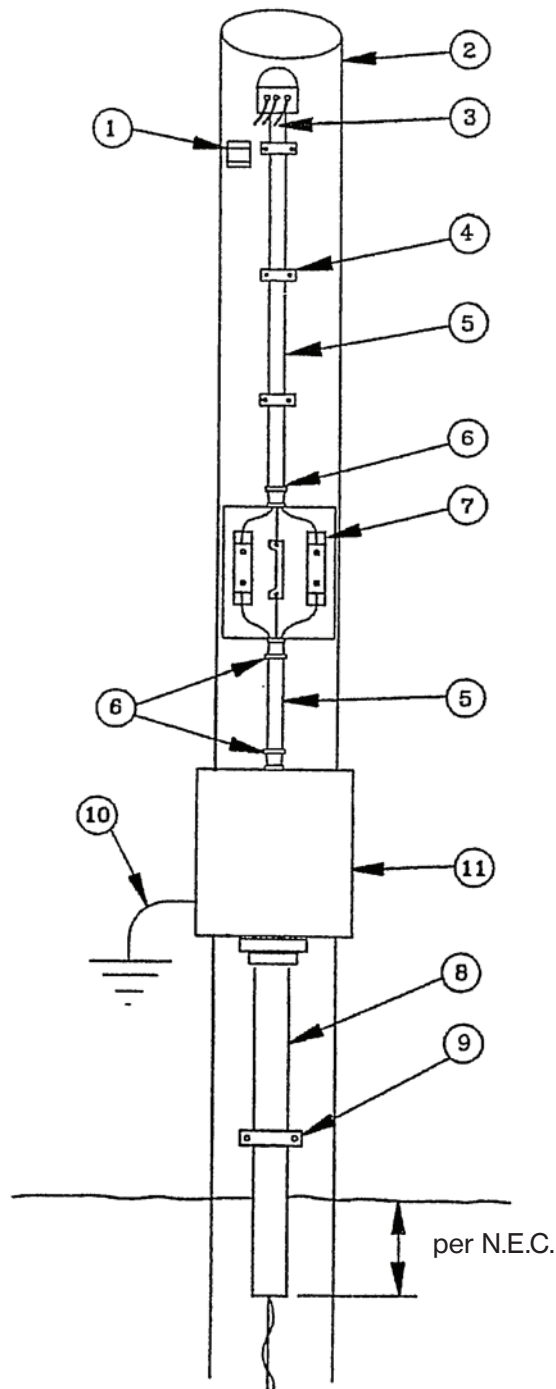

1. Clevis provided by AES Ohio and installed by customer.
2. Utility pole, minimum overall length of 25', provided and installed by customer.
3. Customer's conductors per N.E.C., to extend 24" minimum beyond service head. AES Ohio to make connections to the service drop.
4. Cable straps as per N.E.C.
5. Service entrance conductors sized per N.E.C.
6. Watertight connector per AES Ohio specs.
7. AES Ohio approved meter socket provided and installed by customer. Wire termination by electrician. (height from ground shall be 42" min to 66" max)
8. Conduit per N.E.C.
9. Pipe strap as per N.E.C.
10. Grounding conductor as per N.E.C.
11. Disconnect per N.E.C.

Electric construction

SH-12-001

Section: Electric service handbook

Customer center pole transformer rated metering

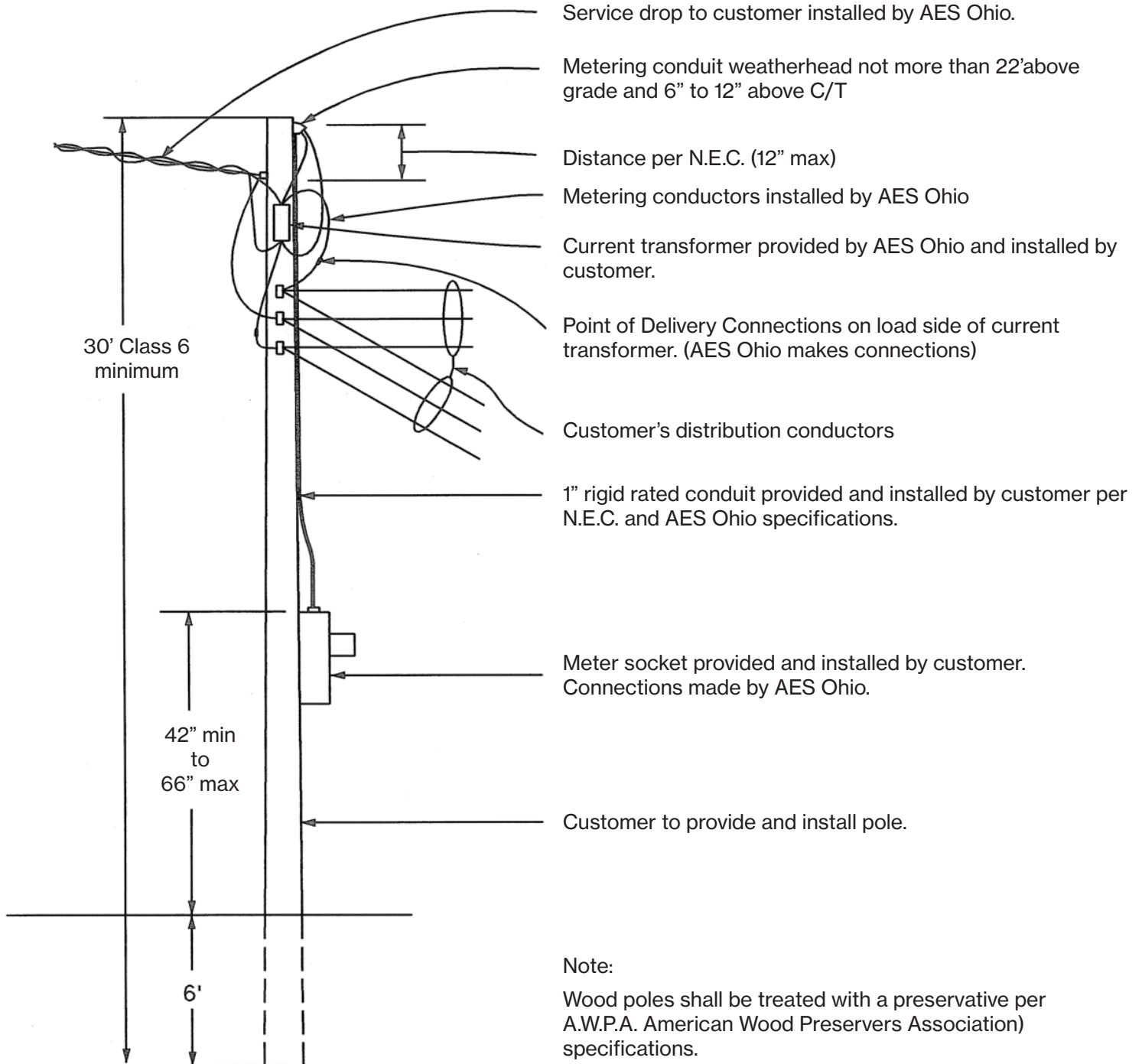

Customer's Meter and Service Pole Meter Self-Contained Installation

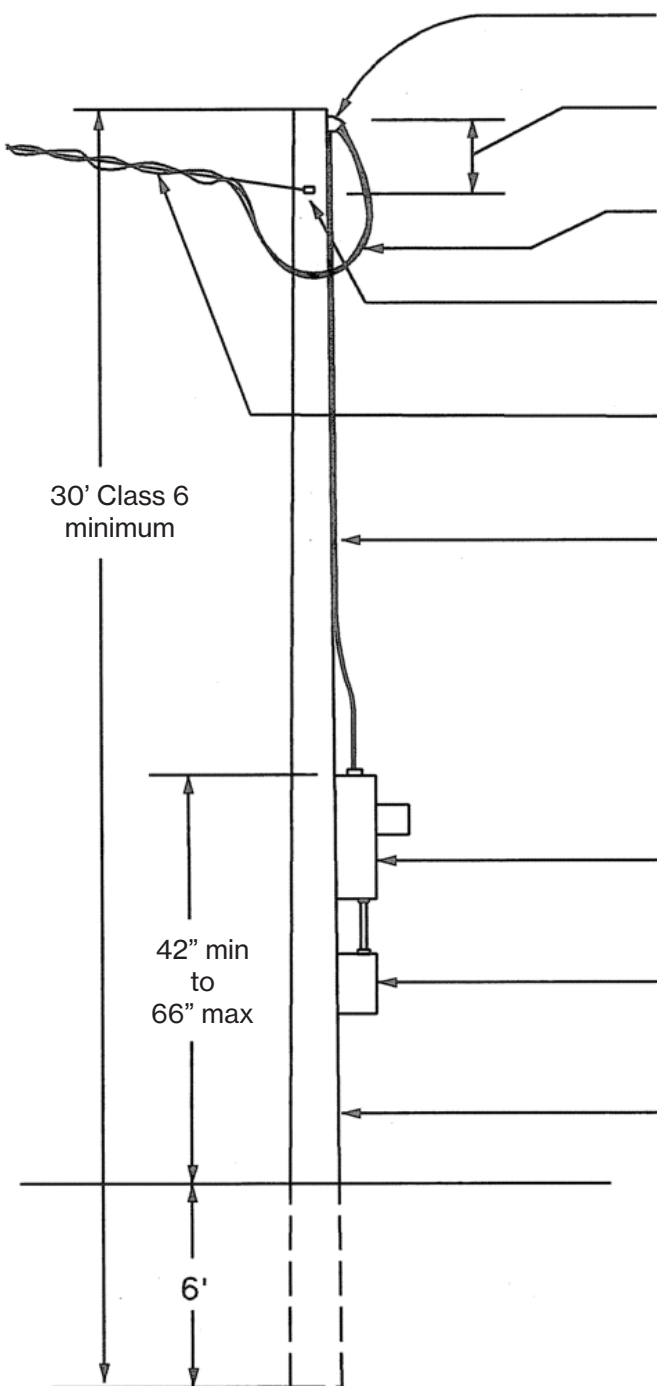

Point of delivery connections at weather head. AES Ohio makes connections

Distance per N.E.C. (12" max)

Customer's conductors shall extend 24 inches minimum from service head.

Insulated weather bracket provided by AES Ohio. Installed by customer per N.E.C.

Service drop to customer's pole installed by AES Ohio

Service conductors provided and installed by customer per N.E.C.

Meter socket provided and installed by customer.

Disconnect Switch per N.E.C

Customer to provide and install pole as specified by AES Ohio.

Note:

Wood poles shall be treated with a preservative per A.W.P.A. (American Wood Preservers Association) specifications.

Electric construction

SH-13-001

Section: Electric service handbook

Commercial Grouped Meter Centers 200A and Less

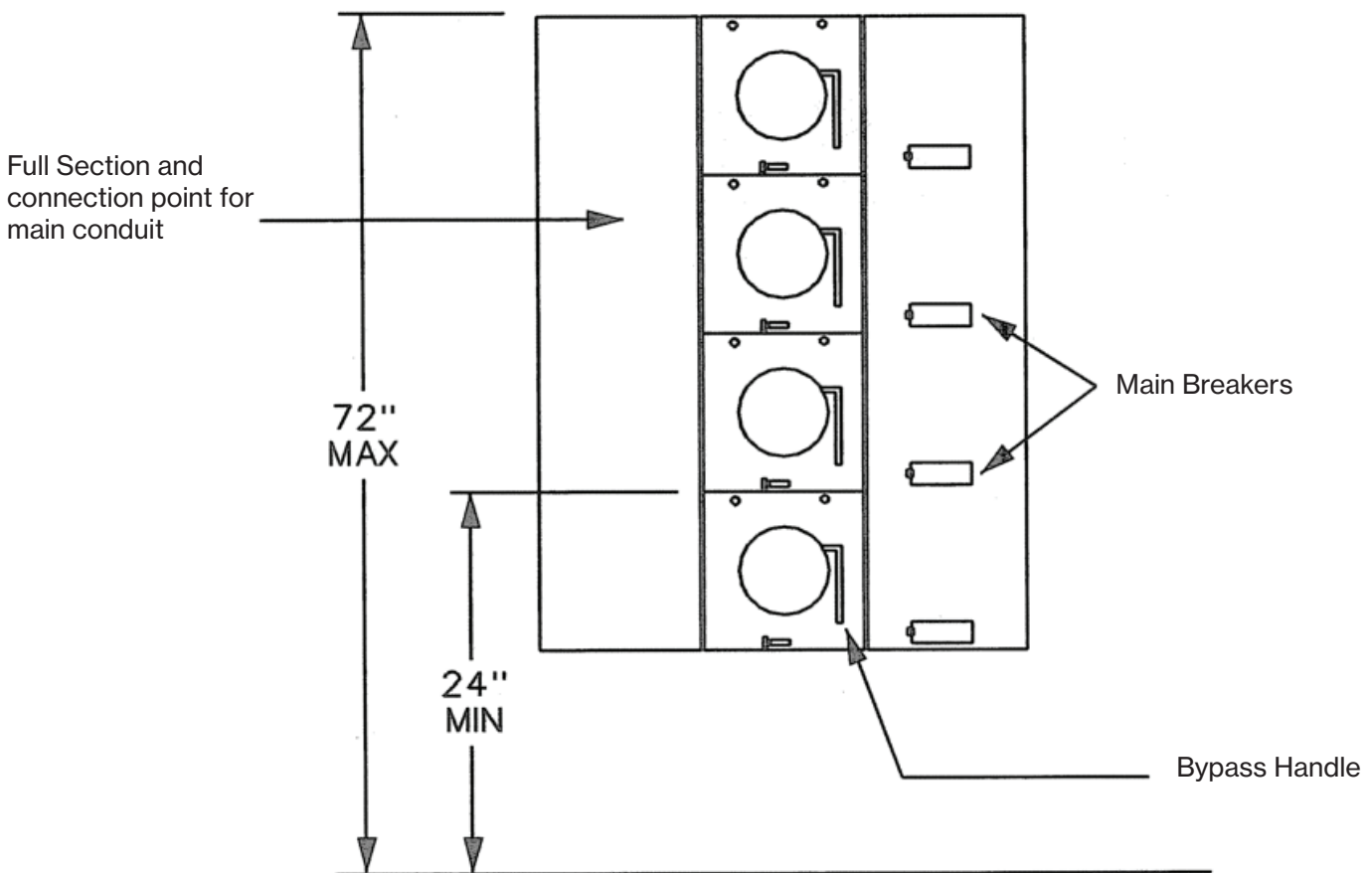

Notes:

- A. All 1Ø and 3Ø commercial grouped meter centers will have a bypass handle for each meter. This applies to overhead and underground services.
- B. Permanent weatherproof mastic back tags shall be attached for identification on each meter position. The actual area served must be identically marked before meter is installed.
- C. Each meter must have its own individual, sealable cover plate. There shall be no cover plates common to two (2) or more meter positions.
- D. For additional specifications, contact the AES Ohio Electric Meter Department.
- E. No 480V Meter Centers.

Contacts

aes-ohio.com/construction

Construction control center: 800-424-5578

Rev. March-21 Replaces: July-19

Report an outage:

877-468-8243

www.aes-ohio.com

aes Ohio

GenerLink™ transfer switch

Meter socket based transfer switches for use with portable emergency generators from GenerLink™ are approved for use with AES Ohio's electric meters provided certain conditions are met:

1. The customer completes and signs an Installation agreement with AES Ohio for the GenerLink™ transfer switch and agrees to pay an installation fee to AES Ohio.
2. The customer purchases the GenerLink™ transfer switch from their supplier. (Global Power Products, Inc.)
3. Global Power Products will send the GenerLink™ transfer switch to AES Ohio Electric Meter department for installation.

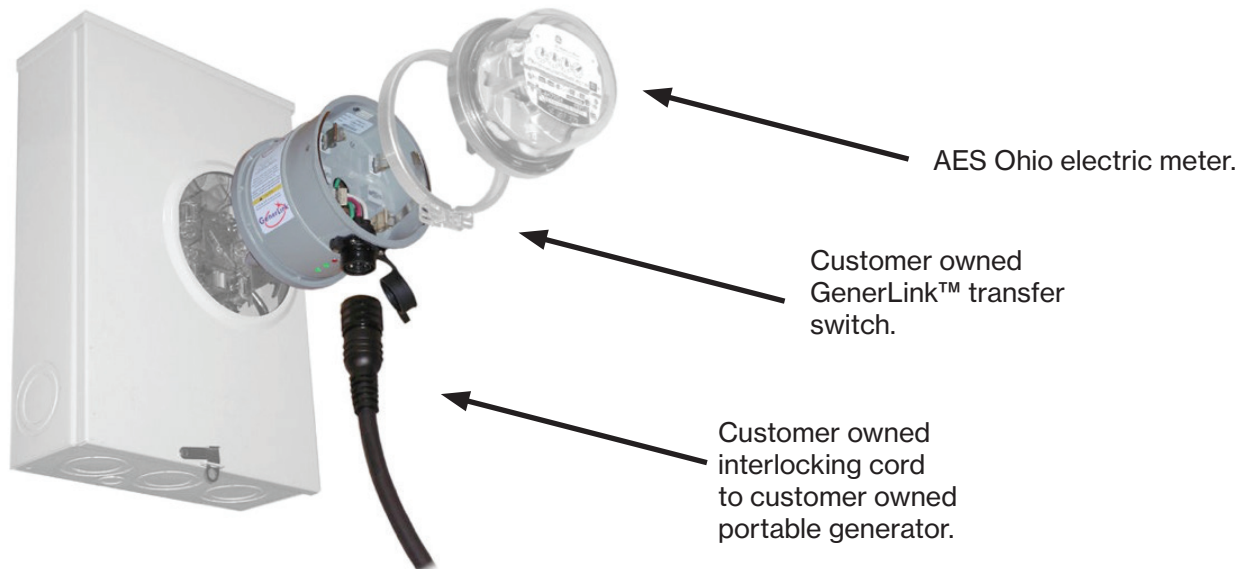

www.generlink.com

Notes:

- F. The customer retains ownership and responsibility for the maintenance of the GenerLink™ switch.
- G. The customer provides the portable emergency generator and the customer is responsible for all operation and maintenance of the portable emergency generator.
- H. AES Ohio retains the right to temporarily remove the GenerLink™ switch for any testing or maintenance purposes that it deems necessary or desirable.
- I. The size of the emergency portable generator is limited by the GenerLink™ switch. Contact GenerLink for details. It may not be possible to supply power to all desired customer loads.
- J. Any installation/removal of the GenerLink™ switch shall be performed by AES Ohio.
- K. For additional information and/or installation, contact the AES Ohio Electric Meter Department.

Contacts

aes-ohio.com/construction

Construction control center: 800-424-5578

Rev. March-21 Replaces: July-19

Report an outage:

877-468-8243

www.aes-ohio.com

Electric construction

SH-98-001

Section: Electric service handbook

Service lateral requirements for residential – 1 family URD

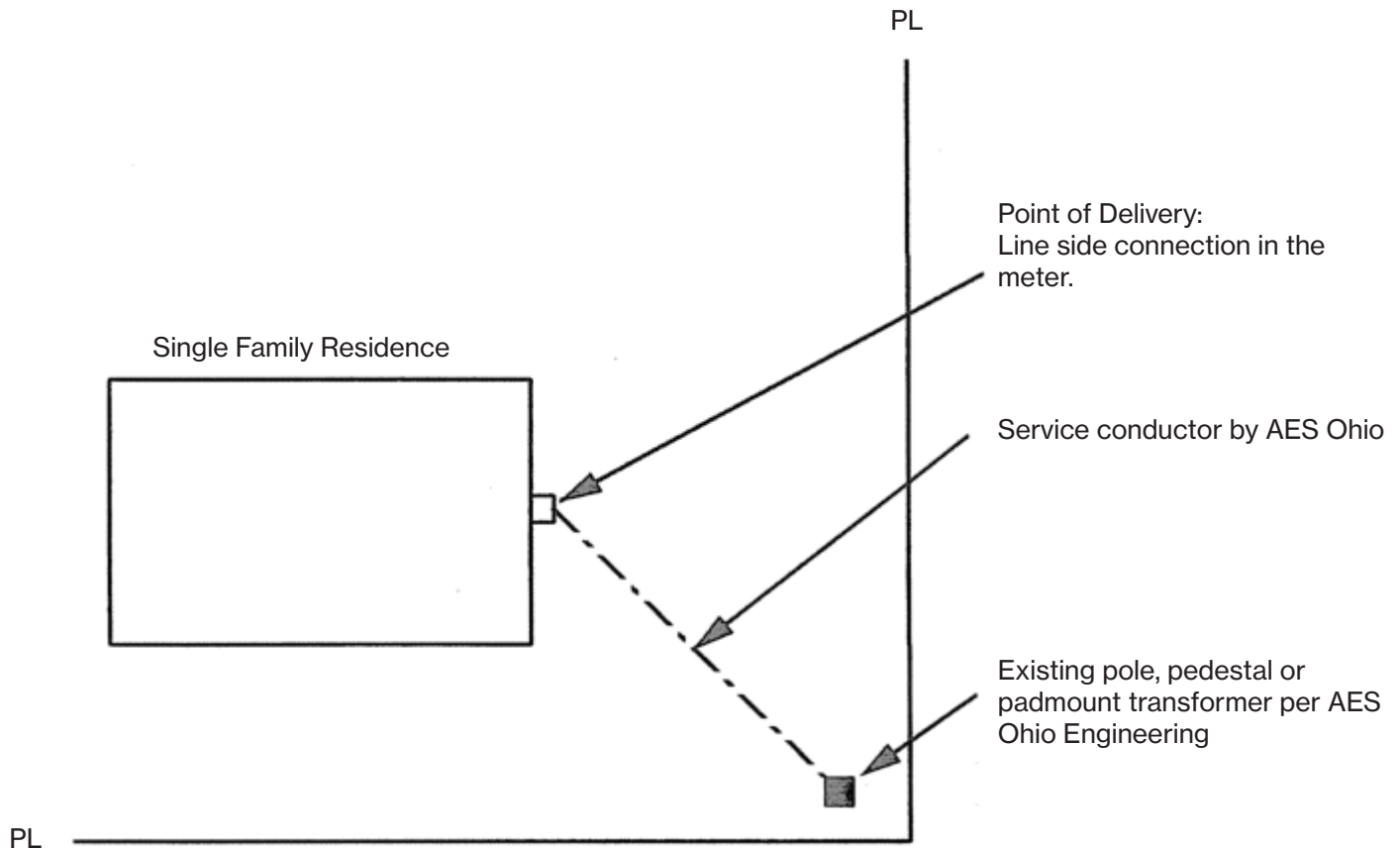

- A. Point of service to be designated by AES Ohio.
- B. Meter socket provided and installed by customer.
- C. Customer trenches and backfills.
- D. AES Ohio to install service conductor.
- E. Customer to furnish and install laced conduits under decks, paved areas and concrete, size to be specified by AES Ohio.

Electric construction

SH-98-003

Section: Electric service handbook

Service lateral requirements for residential – multiple meter center-URD

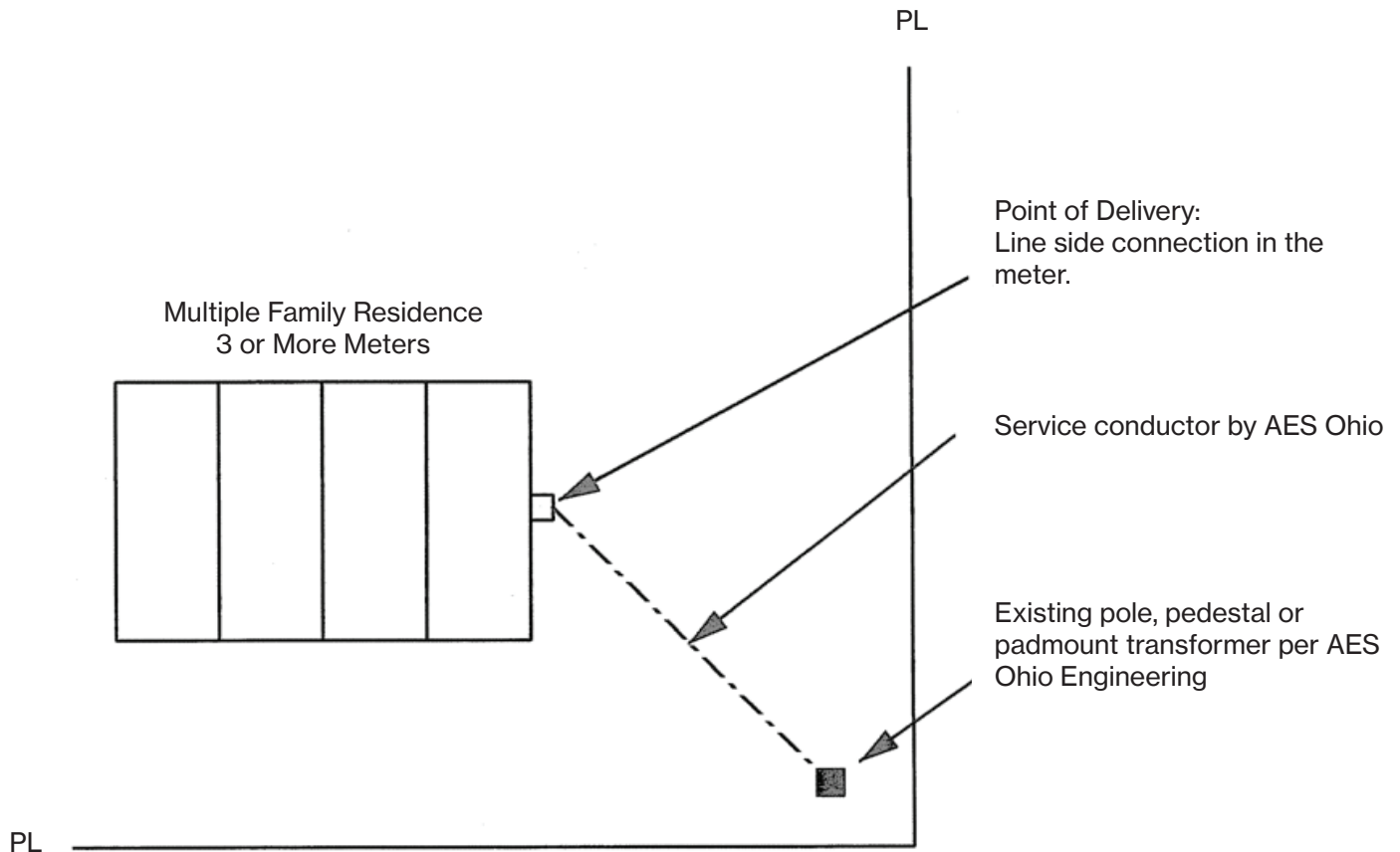

- A. Point of service to be designated by AES Ohio.
- B. Meter center provided and installed by customer. Installation and location to be approved by AES Ohio.
- C. Main disconnect (when used) furnished and installed by customer.
- D. Customer trenches and backfills.
- E. AES Ohio to install service conductor.
- F. Point of delivery becomes line side terminals of main line disconnect switch ahead of the meter center.
- G. Customer to furnish and install laced conduits under decks, concrete and paved areas, size to be specified by AES Ohio.
- H. Permanent weatherproof mastic back tags shall be attached for identification on each meter position. The actual area served must be identically marked before meter is installed.

Contacts

aes-ohio.com/construction

Construction control center: 800-424-5578

Rev. March-21

Replaces: July-19

Report an outage:

877-468-8243

www.aes-ohio.com

aes Ohio

Customer service lateral requirements commercial, single meter-URD

Commercial Industrial and Governmental
Single Meter from Existing Facilities

Self Contained Meter or CT Installations

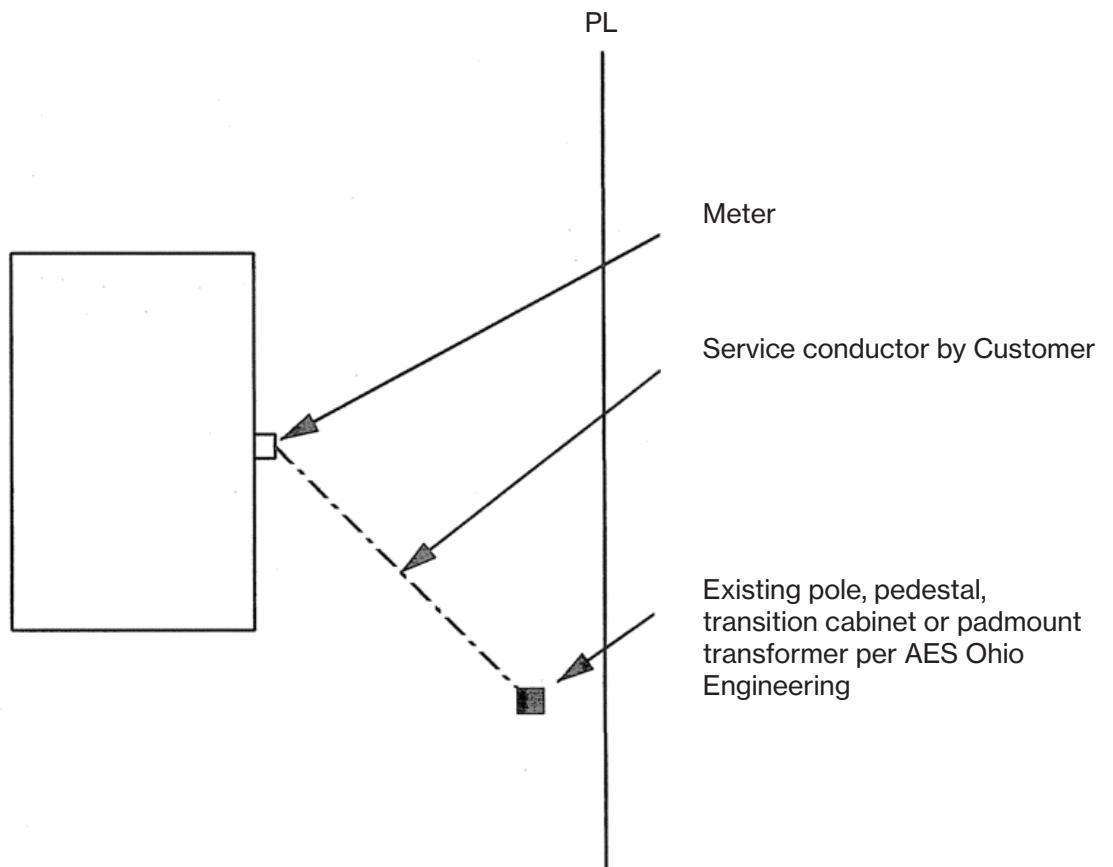

- A. Meter installation and location to be approved by AES Ohio.
- B. Point of delivery is AES Ohio equipment where customer service conductors are connected by AES Ohio.
- C. Customer trenches and backfills.
- D. Service conductor provided and installed by customer.

Customer service lateral requirements commercial, single meter-URD

Commercial Industrial and Governmental
Single Meter from New Facilities

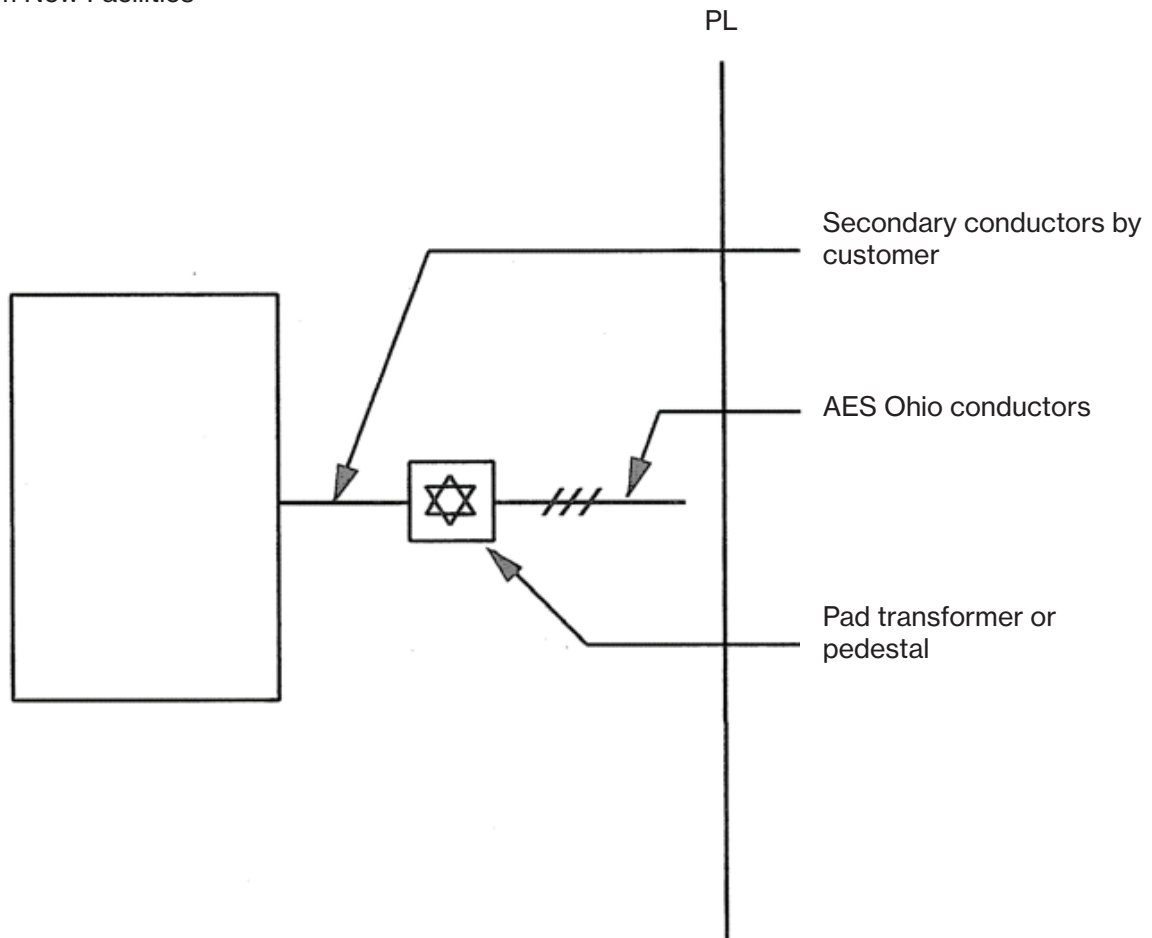

- A. Customer installs a transformer pad per AES Ohio standards. AES Ohio approves location.
- B. The point of delivery is the secondary terminals of the transformer or pedestal.
- C. AES Ohio installs transformer or pedestals and makes all connections in AES Ohio equipment.
- D. Secondary conductors provided and installed by customer per N.E.C.
- E. Meter Socket and/or CT cabinet furnished and installed by customer.
- F. Customer to furnish and install laced conduits under decks, concrete and paved areas for AES Ohio conductors, size to be specified by AES Ohio.

Note: Meter installation and location to be approved by AES Ohio.

Electric construction

SH-98-006

Section: Electric service handbook

Customer service lateral requirements commercial, multi meter center-URD

Commercial Industrial and Governmental
Multi Meter from Existing Facilities

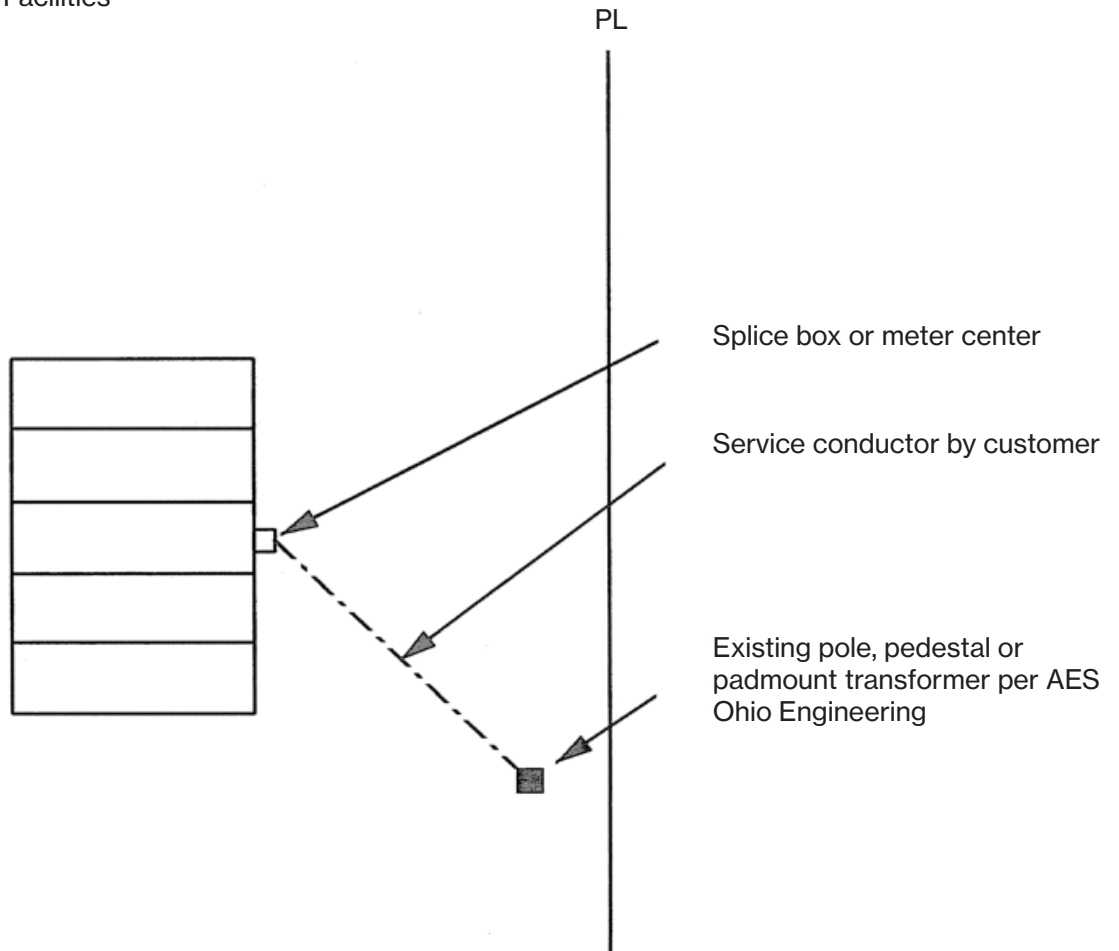

- A. Meter installation and locations to be approved by AES Ohio.
- B. Splice box or meter center furnished and installed by customer.
- C. Customer trenches and backfills.
- D. Service conductor provided and installed by customer per N.E.C. AES Ohio makes all connections at the transformer or pedestal.

Customer service lateral requirements commercial, multi meter center-URD

Commercial industrial and governmental
single meter from new facilities

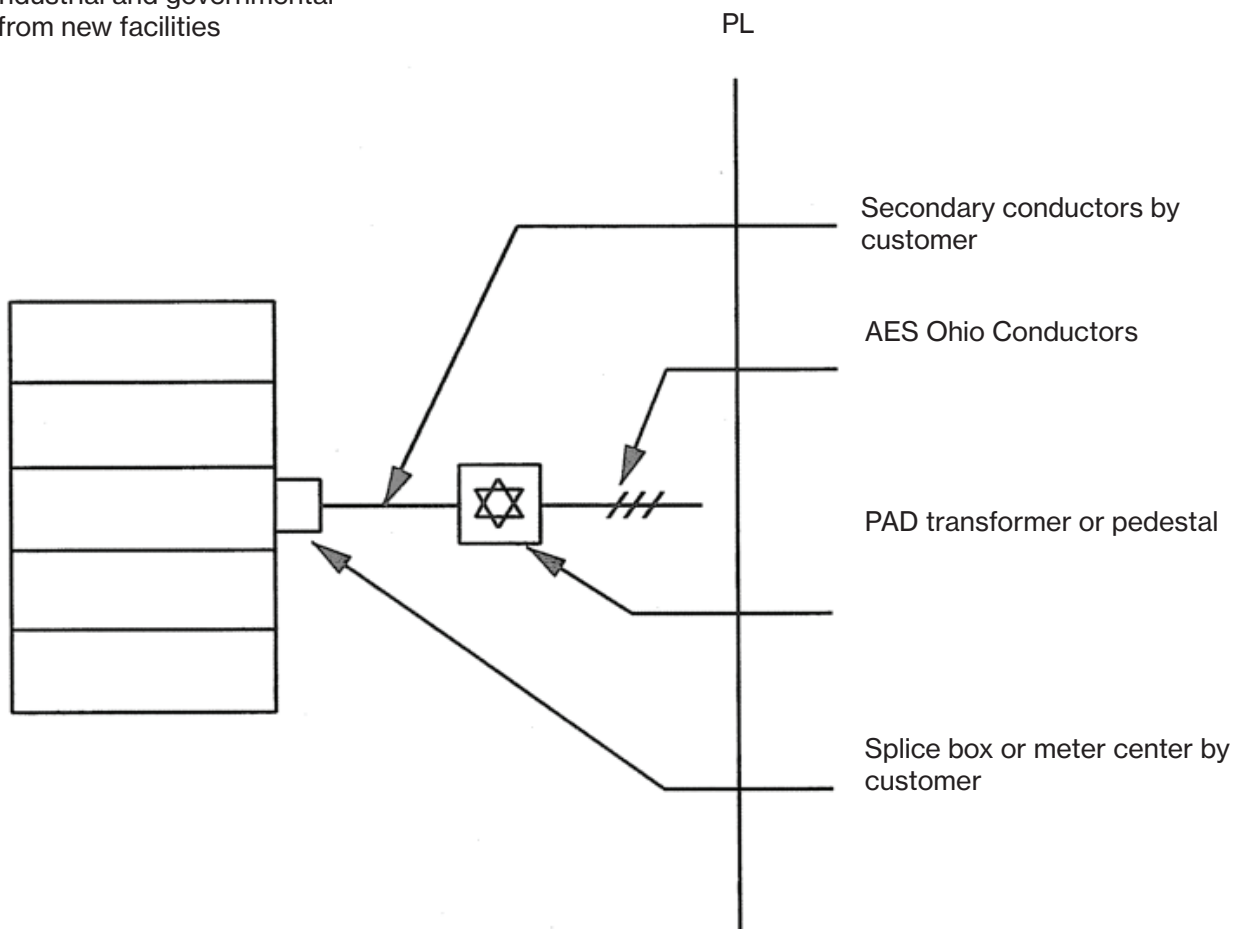

- A. Customer installs a transformer pad per AES Ohio standards. AES Ohio approves location.
- B. Meter installation and locations to be approved by AES Ohio.
- C. Secondary conductors provided and installed by the customer per N.E.C. AES Ohio makes all connections at the transformer or pedestal.
- D. Customer to furnish and install laced conduits under decks, concrete and paved areas for AES Ohio conductors, size to be specified by AES Ohio.

Customer service lateral requirements commercial, many service conductors

Commercial Industrial and Governmental
When the Number of Service Conductors Exceeds
The Physical Limitations of the Padmount Transformer

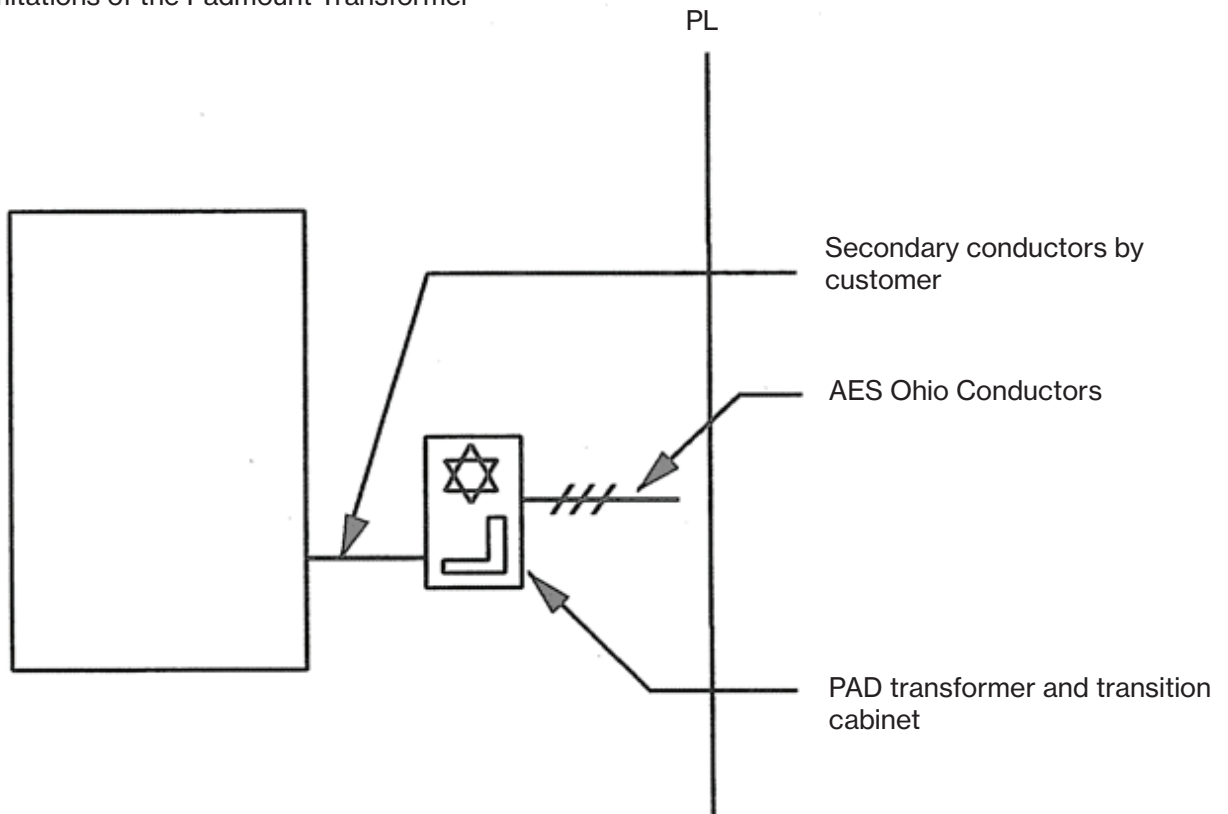

- A. Customer installs a pad per AES Ohio standards. AES Ohio approves location.
- B. Transition cabinet by customer per AES Ohio standards.
- C. The point of delivery is the secondary terminals of the transformer.
- D. AES Ohio installs primary conductors and transformer and makes all connections in the transformer.
- E. Customer to provide and install conductors from transformer to transition cabinet. AES Ohio shall specify conductor size.
- F. Secondary conductors from transition cabinet to Service entrance equipment provided and installed by customer per N.E.C.
- G. Customer to furnish and install laced conduits under decks, concrete and paved areas for AES Ohio conductors, size to be specified by AES Ohio.
- H. Meter installation and location to be approved by AES Ohio.